

Instruction Manual

SR SERIES

High Voltage Power Supply

MODEL : XXXXX
SERIAL# : XXXXX
DATE : XXXXX

SPELLMAN
HIGH VOLTAGE ELECTRONICS
CORPORATION
475 Wireless Blvd.
Hauppauge, New York, 11788

+1(631) 630-3000*FAX: +1(631) 435-1620*
E-mail: sales@spellmanhv.com
Website: www.spellmanhv.com



- **COMPACT DESIGN AND LIGHTWEIGHT**
- **LOW COST PER WATT**
- **LOW EMI AND RFI**
- **CONSTANT VOLTAGE/CONSTANT CURRENT OPERATION WITH AUTOMATIC CROSSOVER**
- **ARC DETECT, ARC QUENCH AND ARC COUNT**
- **OEM CUSTOMIZATION AVAILABLE**

www.spellmanhv.com/manuals/SR

SR power supplies are available in 18 models with voltage outputs ranging from 1kV to 120kV. Similar to the SA power supplies, they incorporate series resonant inverter technology with a patented control circuit. This enables the supplies to operate without damage or interruption in rugged environments that frequently pose threats to conventional high voltage power supplies. In addition, the SR Series protects your load from excessive peak currents by instantaneously limiting the output current when an arcover condition is sensed. Parallel operation options to increase power and current capabilities are available for SR models with power outputs of 12kW, 18kW and higher.

TYPICAL APPLICATIONS

| | |
|-----------------------|--------------------|
| Sputtering | CW Lasers |
| Analytical X-ray | Ion Implantation |
| Electron Beam Systems | Capacitor Charging |
| Radar Modulators | |

OPTIONS

| | |
|---------------|---------------------------|
| 200-1P | 200Vac Single Phase Input |
| 200-3P | 200Vac Three Phase Input |
| 220-1P | 220Vac Single Phase Input |
| AOL | Adjustable Overload Trip |
| FG | Floating Ground |
| CPC | Constant Power Control |
| APT | Adjustable Power Trip |
| RMI | Remote Mode Indicators |
| ROA | Remote Overvoltage Adjust |
| NSS | No Slow Start |
| SS(x) | Nonstandard Slow Start |
| SL | Mounting Slides |
| BFP | Blank Front Panel |
| EFR | External Fault Relay |

SPECIFICATIONS

Input:

208Vac \pm 10%, 50 or 60Hz, three phase.

Output:

18 models from 1kV to 120kV. Each model is available with positive, negative or reversible polarity outputs.

Output Controls:

Voltage and current are continuously adjustable over entire range via ten-turn potentiometers with lockable counting dials.

Voltage Regulation:

Load: 0.005% of full voltage +500mV for full load change.
Line: \pm 0.005% of full voltage +500mV over specified input range.

Current Regulation:

Load: 0.05% of full current \pm 100 μ A for any voltage change.
Line: \pm 0.05% of full current over specified input range.

Ripple:

0.1% p-p +1Vrms for three phase models only.
0.1%rms +1Vrms for single phase models only.

Temperature Coefficient:

100ppm/ $^{\circ}$ C. Higher Stability (50ppm/ $^{\circ}$ C) available on special order.

Stability:

0.01%hr. after 1/2 hour warm-up, 0.02% per 8 hrs. (typical).

Operating Temperature:

0 $^{\circ}$ C to +40 $^{\circ}$ C

Storage Temperature:

-40 $^{\circ}$ C to +85 $^{\circ}$ C

Humidity:

10% to 90% RH, non-condensing

Metering:

Digital voltage and current meters, 1% accuracy.

System Status Display:

"Dead Front" type indicators provide status of up to 14 system operations including voltage and current regulation, fault conditions and circuit control.

Output Cable:

10 ft (3.05m) shielded high voltage cable, removable at rear panel.

Dimensions:

10 $\frac{1}{2}$ "(6U)H x 19"W x 19"D rack mount, 1kV to 70kV.
(26.7cm x 48.3cm x 48.3cm)
10 $\frac{1}{2}$ "(6U)H x 19"W x 24"D rack mount, 80kV to 120kV.
(26.7cm x 48.3cm x 61.0cm)

Regulatory Approvals:

Compliant to 2004/108/EC, the EMC Directive and 2006/95/EC, the Low Voltage Directive.

SR SELECTION TABLE

| MAXIMUM RATING | | MODEL NUMBER |
|----------------|------|--------------|
| kV | mA | |
| 1 | 6000 | SR1PN6 |
| 2 | 3000 | SR2PN6 |
| 3 | 2000 | SR3PN6 |
| 6 | 1000 | SR6PN6 |
| 8 | 750 | SR8*6 |
| 10 | 600 | SR10*6 |
| 12 | 500 | SR12*6 |
| 15 | 400 | SR15*6 |
| 20 | 300 | SR20*6 |
| 30 | 200 | SR30*6 |
| 40 | 150 | SR40*6 |
| 50 | 120 | SR50*6 |
| 60 | 100 | SR60*6 |
| 70 | 85 | SR70*6 |
| 80 | 75 | SR80*6 |
| 100 | 60 | SR100*6 |
| 110 | 55 | SR110*6 |
| 120 | 50 | SR120*6 |

*Specify "P" for positive, "N" for negative, or "PN" for reversible polarity. Higher voltage or intermediate voltage models available on special order. From 1kV to 6kV, reversible polarity is accomplished by changing a rear panel link. From 8kV to 120kV, polarity is reversed by exchanging internal high voltage assemblies.

SR TERMINAL BLOCK 18 PIN

| TB1 | SIGNAL |
|-----|-------------------------|
| 1 | P.S. Common |
| 2 | Inhibit |
| 3 | External Interlock In |
| 4 | External Interlock Out |
| 5 | mA Test point Out |
| 6 | kV Test point Out |
| 7 | +10Vdc Reference |
| 8 | mA Program In |
| 9 | Local mA Program Out |
| 10 | kV Program In |
| 11 | Local kV Program Out |
| 12 | Remote Pwr On In |
| 13 | Remote Pwr On Out |
| 14 | Remote HV Off |
| 15 | Remote HV Off/On Common |
| 16 | Remote HV On |
| 17 | HV Off Indicator |
| 18 | HV On Indicator |



DIMENSIONS: in.,[mm]

FRONT VIEW

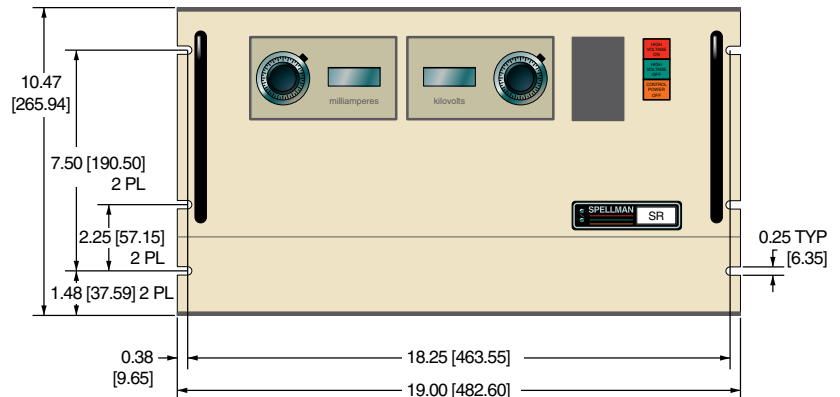

TOP VIEW

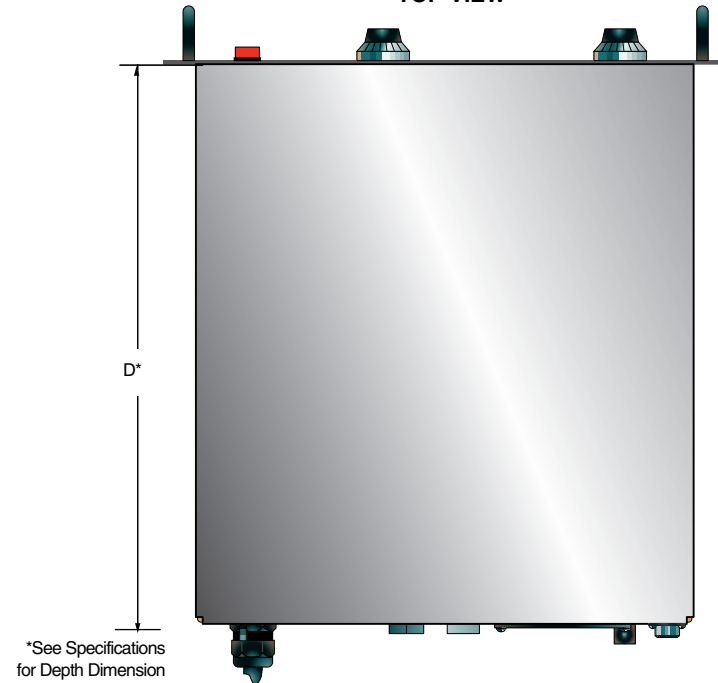

BACK VIEW

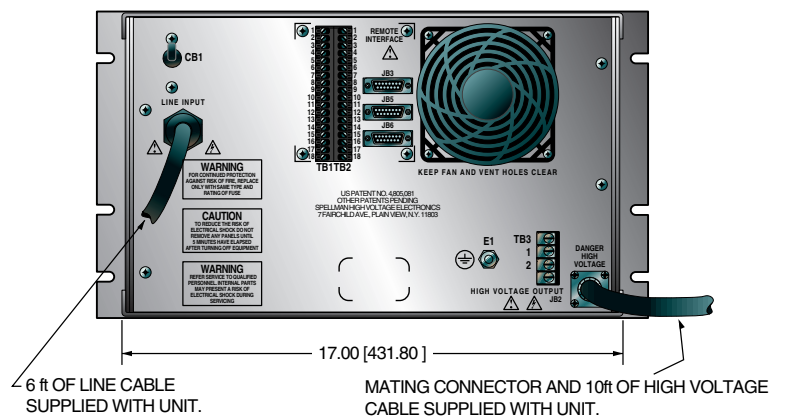

IMPORTANT SAFETY PRECAUTIONS

SAFETY

THIS POWER SUPPLY GENERATES VOLTAGES THAT ARE DANGEROUS AND MAY BE FATAL.
OBSERVE EXTREME CAUTION WHEN WORKING WITH THIS EQUIPMENT.

High voltage power supplies must always be grounded.

Do not touch connections unless the equipment is off and the Capacitance of both the load and power supply is discharged.

Allow five minutes for discharge of internal capacitance of the power supply.

Do not ground yourself or work under wet or damp conditions.

SERVICING SAFETY

Maintenance may require removing the instrument cover with the power on.

Servicing should be done by qualified personnel aware of the electrical hazards.

WARNING note in the text call attention to hazards in operation of these units that could lead to possible injury or death.

CAUTION notes in the text indicate procedures to be followed to avoid possible damage to equipment.

Copyright © 2000, Spellman High Voltage Electronics Corporation. All Rights Reserved.
This information contained in this publication is derived in part from proprietary and patent data. This information has been prepared for the express purpose of assisting operating and maintenance personnel in the efficient use of the model described herein, and publication of this information does not convey any right to reproduce it or to use it for any purpose other than in connection with installation, operation, and maintenance of the equipment described.

WICHTIGE SICHERHEITSHINWEISE

SICHERHEIT

DIESES HOCHSPANNUNGSNETZTEIL ERZEUGT LEBENSGEFÄHRLICHE HOCHSPANNUNG.
SEIN SIE SEHR VORSICHTIG BEI DER ARBEIT MIT DIESEM GERÄT.

Das Hochspannungsnetzteil muß immer geerdet sein.

Berühren Sie die Stecker des Netzteiles nur, wenn das Gerät ausgeschaltet ist und die elektrischen Kapazitäten des Netzteiles und der angeschlossenen Last entladen sind.

Die internen Kapazitäten des Hochspannungsnetzteiles benötigen ca. 5 Minuten, um sich zu entladen.

Erden Sie sich nicht, und arbeiten Sie nicht in feuchter oder nasser Umgebung.

SERVICESICHERHEIT

Notwendige Reparaturen können es erforderlich machen, den Gehäusedeckel während des Betriebes zu entfernen.

Reparaturen dürfen nur von qualifiziertem, eingewiesenem Personal ausgeführt werden.

“WARNING” im folgenden Text weist auf gefährliche Operationen hin, die zu Verletzungen oder zum Tod führen können.

“CAUTION” im folgenden Text weist auf Prozeduren hin, die genauestens befolgt werden müssen, um eventuelle Beschädigungen des Gerätes zu vermeiden.

PRECAUTIONS IMPORTANTES POUR VOTRE SECURITE

CONSIGNES DE SÉCURITÉ

CETTE ALIMENTATION GÉNÈRE DES TENSIONS QUI SONT DANGEUREUSES ET PEUVENT ÊTRE FATALES.
SOYEZ EXTRÊMEMENT VIGILANTS LORSQUE VOUS UTILISEZ CET ÉQUIPEMENT.

Les alimentations haute tension doivent toujours être mises à la masse.

Ne touchez pas les connectiques sans que l'équipement soit éteint et que la capacité à la fois de la charge et de l'alimentation soient déchargées.

Prévoyez 5 minutes pour la décharge de la capacité interne de l'alimentation.

Ne vous mettez pas à la masse, ou ne travaillez pas sous conditions mouillées ou humides.

CONSIGNES DE SÉCURITÉ EN CAS DE REPARATION

La maintenance peut nécessiter l'enlèvement du couvercle lorsque l'alimentation est encore allumée.

Les réparations doivent être effectuées par une personne qualifiée et connaissant les risques électriques.

Dans le manuel, les notes marquées « **WARNING** » attire l'attention sur les risques lors de la manipulation de ces équipements, qui peuvent entraîner de possibles blessures voire la mort.

Dans le manuel, les notes marquées « **CAUTION** » indiquent les procédures qui doivent être suivies afin d'éviter d'éventuels dommages sur l'équipement.

IMPORTANTI PRECAUZIONI DI SICUREZZA

SICUREZZA

QUESTO ALIMENTATORE GENERA TENSIONI CHE SONO PERICOLOSE E POTREBBERO ESSERE MORTALI.
PONI ESTREMA CAUTELA QUANDO OPERI CON QUESTO APPARECCHIO.

- Gli alimentatori ad alta tensione devono sempre essere collegati ad un impianto di terra.
- Non toccare le connessioni a meno che l'apparecchio sia stato spento e la capacità interna del carico e dell'alimentatore stesso siano scariche.
- Attendere cinque minuti per permettere la scarica della capacità interna dell'alimentatore ad alta tensione.
- Non mettere a terra il proprio corpo oppure operare in ambienti bagnati o saturi d'umidità.

SICUREZZA NELLA MANUTENZIONE.

- Manutenzione potrebbe essere richiesta, rimuovendo la copertura con apparecchio acceso.
- La manutenzione deve essere svolta da personale qualificato, coscio dei rischi elettrici.
- Attenzione alle **AVVERTENZE** contenute nel manuale, che richiamano all'attenzione ai rischi quando si opera con tali unità e che potrebbero causare possibili ferite o morte.
- Le note di **CAUTELA** contenute nel manuale, indicano le procedure da seguire per evitare possibili danni all'apparecchio.

Table of Contents

PAGE

| | |
|---|----|
| 1. INTRODUCTION | |
| 1.1 Description of the SR Series | 1 |
| 1.2 SR Specifications | 1 |
| 1.3 Standard Features..... | 1 |
| 1.3.1 Remote Operating Features..... | 2 |
| 1.3.2 System Status and Fault Diagnostic Display | 2 |
| 1.4 Options..... | 3 |
| 1.5 Interpreting the Model Number | 3 |
| 2. INSPECTION & INSTALLATION | |
| 2.1 Initial Inspection | 4 |
| 2.2 Mechanical Installation..... | 4 |
| 3. OPERATING INSTRUCTIONS | |
| 3.1 Operation..... | 6 |
| 3.2 Standard Features..... | 7 |
| 4. PRINCIPLES OF OPERATION | |
| 4.1 Chassis | 13 |
| 4.2 Line Rectifier and Filtering..... | 13 |
| 4.3 Inverter..... | 14 |
| 4.4 High Voltage Transformer..... | 15 |
| 4.5 High Voltage Assembly..... | 15 |
| 4.6 System Control PWB..... | 15 |
| 4.7 Front Panel Assembly | 16 |
| 4.8 Rear Panel Interface PWB | 16 |
| 4.9 Options..... | 16 |
| 5. OPTIONS | |
| 5.1 Adjusting Overload Trip..... | 17 |
| 5.2 220C AC Single Phase Input | 17 |
| 5.3 No Slow Start..... | 17 |
| 5.4 Non-Standard Slow Start | 17 |
| 5.5 Extra Length Output Cable..... | 17 |
| 5.6 Slides..... | 17 |
| 5.7 Remote Over Voltage Adjust..... | 17 |
| 5.8 Remote Mode Indicators..... | 17 |
| 5.9 Floating Ground..... | 17 |
| 5.10 Adjustable Power Trip/Constant Power Control | 19 |
| 5.11 Custom Designed Models | 19 |
| 5.12 Parallel Option (12KW)..... | 20 |
| 5.13 Parallel Option (18KW)..... | 24 |
| 5.14 Reversible Polarity Option (PN)..... | 25 |

| | | |
|-----------|---|----|
| 5.15 | External Fault Relay | 25 |
| 5.16 | External ARC Limiter and kV Feedback Chassis | |
| 6. | MAINTENANCE | |
| 6.1 | Periodic Servicing | 27 |
| 6.2 | Performance Test | 27 |
| 6.3 | High Voltage Dividers | 27 |
| 7. | REPLACEMENT PARTS | |
| 7.1 | Replacement Parts | 28 |
| 7.2 | Correspondence and Ordering Spare Parts | 28 |
| 8. | FACTORY SERVICE | |
| 8.1 | Warranty Repairs | 29 |
| 8.2 | Factory Service Procedures | 29 |
| 8.3 | Ordering Options and Modifications | 29 |
| 8.4 | Shipping Instructions | 29 |

APPENDIX

- A. Specification Controls (Custom Models Only)
- B. Schematics

LIST OF FIGURES

| | | |
|-------------|--|----|
| Figure 2.1 | Dimensions | 5 |
| Figure 3.1 | Typical Operating Setup | 8 |
| Figure 3.2A | Remote Programming via Voltage Source | 9 |
| Figure 3.2B | Remote Programming via External Resistance | 9 |
| Figure 3.3 | Remote Monitor Test Point Designations | 10 |
| Figure 3.4 | Remote Control Power On, HV ON and HV OFF | 10 |
| Figure 3.5 | External Inhibit Interface Circuit | 11 |
| Figure 3.6 | External Interlock Interface Circuit | 11 |
| Figure 3.7 | Remote HV ON and Remote HV OFF Indicator Circuit | 12 |
| Figure 5.1 | Remote Overvoltage Adjust Interface | 18 |
| Figure 5.2 | Remote Mode Indicators Interface | 18 |
| Figure 5.3 | Floating Ground Interface Circuit | 19 |
| Figure 5.4 | Adjustable Power Remote Interface | 20 |
| Figure 5.5 | 12kW Installation Drawing | 21 |
| Figure 5.6 | 18kW Installation Drawing | 23 |
| Figure 5.7 | Rear Panel Polarity Reversal Switch | 25 |
| Figure 5.8 | 12kW Installation with kV Feedback Chassis | 26 |

LIST OF TABLES

| | | |
|-----------|-------------------------------|----|
| Table 1.1 | Options | 3 |
| Table 4.1 | List of Main Assemblies | 14 |

Chapter 1

INTRODUCTION

1.1 Description of the SR Series

The SR series of high voltage power supplies provides very well regulated, low ripple high voltage in a highly efficient, compact design. The improvements in size and performance over traditionally designed high voltage power supplies are due to the series resonant topology and unique control circuitry of the SR design. The currents in the power circuits are sinusoidal, starting and stopping at zero. This zero current switching eliminates undesirable electromagnetic radiation and minimizes switching losses normally associated with switching regulators. A patented control system maintains a constant frequency over the operating output range. Constant frequency operation allows a dynamic response time of less than 5 milliseconds, and one of the lowest ripple specifications in the industry at this power level. The combination of the patented control system and proprietary protection circuitry enables the supplies to operate under arcing and extreme transient conditions without damage of interruptions.

The DC output voltage and current are continuously adjustable from zero to the maximum rating via two front panel ten turn locking potentiometers. These high voltage power supplies have 0.005% load regulation, 0.005% line regulation, and 0.1% P-P ripple..

The supplies operate from a 208 Volt three phase AC line and are fan cooled. Other line voltages are available. Options are listed in Table 1.1 and described in Section 5. Custom designed units to meet special needs are also available.

The standard warranty applies to standard SR units. Consult factory about the warranty for custom SR units.

1.2 SR Specifications

- **Output Control:** Voltage and current are continuously adjustable over the entire range from zero to maximum rating a ten-turn potentiometer with a lockable counting dial.
- **Input Voltage:** 208 Volts AC $\pm 10\%$, 50/60Hz, three phase. Other input voltages are available on request.
- **Voltage Regulation:**
Load Regulation: 0.005% of full voltage +500mV for a no load to full load change.

Line Regulation: 0.005% of full voltage +500mV over the specified input voltage range.

- **Current Regulation:**
Load Regulation: 0.05% \pm of full current $\pm 100\mu\text{A}$ for any voltage change.
Line Regulation: $\pm 0.05\%$ of full current over the specified input voltage range.
- **Ripple:**
0.1% P-P +1V_{rms} of rated output voltage for three phase input models.
0.1% rms +1V_{rms} of rated output voltage for single phase input models.
- **Polarity:** Positive, Negative, and Reversible polarity with respect to ground are available.
- **Stability:** 0.01% per hour after 1/2 hour warm up. 0.02% per 8 hours (typical).
- **Temperature Coefficient:** 100 ppm per °C. Higher stability (50 ppm per °C) available on special order.
- **Ambient Temperature:**
Operating: -20°C to +40°C
Storage: -40°C to +85°C
- **Metering:** Digital voltage and current meters are accurate to 1%.
- **Weight:** 75 lbs. (typical)
- **Physical:**
1kV - 70kV: 10½”H x 19”W x 19”D rack mount.
80kV - 120V: 10½”H x 19”W x 24”D rack mount.

1.3 Standard Features

The SR series incorporates several standard features designed to optimize user satisfaction and safety.

SLOW START: This feature provides a gradual increase in high voltage until the preset operating point is reached. The slow start time is factory set for 6 seconds. Other slow start times are available as an option.

ARC DETECT / ARC QUENCH / ARC COUNT:

These features allow the user to tailor the power supply to meet specific needs in dynamic load applications. If an arc occurs, the output is inhibited for approximately one second, then the output is ramped up to the preset level with the Slow-start circuitry. See Chapter 3 for operating details and information for user customization for these features.

INTERNAL FAULT PROTECTION: The SR series continually monitors internal circuits critical to the proper operation of the power supply. In the event that one of these circuits does not function correctly, the fault detection circuit turns off the output and reverts the unit to the POWER DOWN mode.

INDICATOR LAMPS: CONTROL POWER ON, HIGH VOLTAGE OFF and HIGH VOLTAGE ON indicators are equipped with dual lamps for safety.

OUTPUT CABLE: All models are provided with a ten foot shielded high voltage output cable. The cables are designed with a plug arrangement so that they can be easily removed from the mating receptacle located on the rear of the chassis.

1.3.1 Remote Operating Features

REMOTE PROGRAMMING: Allows remote adjustment of the output voltage and current via an external voltage source. The output power is also remotely controllable when the CPC or APT option is ordered.

REMOTE MONITOR: Allows remote monitoring of the output voltage and current. NOTE: Output power remote monitor is included with the CPC and APT options.

REMOTE HIGH VOLTAGE CONTROL: Allows remote control of the HIGH VOLTAGE ON and HIGH VOLTAGE OFF functions. Signals are also provided for remote indication of HV ON or HV OFF status.

REMOTE POWER ON: Allows remote control of CONTROL POWER ON/OFF functions. This feature also allows remote reset of the power supply in case of SYSTEM FAULT shutdown.

REMOTE POWER ON STATUS: This signal indicates the status of the POWER ON control. This signal also provides indication of a SYSTEM FAULT shutdown (optional).

EXTERNAL INHIBIT: A circuit that will inhibit the high voltage output is provided on the terminal block TB1 on the rear of the chassis. A logic low, ground, will inhibit the high voltage output and a logic high, open, will

restore the high voltage output to the preset level.

NOTE: The External Inhibit circuit should NOT be used for protection against injury or for safety interlock. See External Interlock for this type of safety control

EXTERNAL INTERLOCK: Interlock connections are provided on the terminal block on the rear of the chassis for connection to a safety switch. The unit will not operate unless the interlock circuit is closed. During high voltage operation, opening the interlock circuit will cause the High Voltage to shut off. This circuit should be used for safety interlock circuits.

1.3.2 System Status and Fault Diagnostic Display

“Dead Front” type indicators are provided to give the user complete indication of system operation and fault conditions. If a fault occurs the power supply will revert to the POWER DOWN mode. This is indicated by a flashing of the CONTROL POWER ON indicator. To reset, depress the CONTROL POWER ON switch.

VOLTAGE (CONTROL): Indicates the output voltage regulator circuit is maintaining voltage regulation.

CURRENT (CONTROL): Indicates the output current regulator circuit is maintaining current regulation.

POWER (CONTROL): Indicates the output power regulator circuit is maintaining power regulation (optional).

HV INHIBIT: Indicates the high voltage supply is being inhibited by either the EXTERNAL INHIBIT or internal protection circuitry.

INTLK CLOSED: Indicates the EXTERNAL INTERLOCK connections are in the closed position. This also indicates closure of internal power supply interlocks, i.e. bottom cover access interlock switch.

INTLK OPEN: Indicates the EXTERNAL INTERLOCK connections are in the open position. This also indicates opening of internal power supply interlocks.

SYSTEM FAULT: Indicates an internal fault, status indicator fault or parallel/filament fault has occurred.

OVERVOLTAGE: Indicates the overvoltage protection circuitry has caused the power supply to turn off. Overvoltage protection is internally set to 105% of rated output voltage or by the remote overvoltage adjust option.

OVERCURRENT: Indicates the output current has exceeded the programmed current trip level when the AOL (Adjustable Overload Trip) or the OL (overload Trip) options are installed.

OVERPOWER: Indicates the output power has exceeded the internally set level or the remote programmed level if the optional circuitry is installed.

ARC: Indicates that an arc has occurred within the previous one second or that the ARC COUNT/TRIP has shutdown the power supply.

RGLT ERR: Indicates a failure in the voltage, current or power regulation circuitry. This fault usually occurs when there is a lack of output power to maintain regulation.

OVR TEMP: Indicates that excessive temperature has been sensed within the chassis and internal protection circuitry has shut down the power supply.

INV FAULT: Indicates a cross-conduction in the inverter

1.4 Options

| CODE | DISCRIPTION |
|---------|-----------------------------------|
| • AOL | Adjustable Overload Trip (0-103%) |
| • ROA | Remote Overvoltage Adjust |
| • RMI | Remote Mode Indicators |
| • FG | Floating Ground |
| • CPC | Constant Power Control |
| • LR | Low Ripple (0.05% P-P) |
| • 220 | 220V AC Single Phase Input |
| • APT | Adjustable Power Trip |
| • NSS | No Slow Start |
| • SS(X) | Non-Standard Slow Start |
| • SL | Slides |
| • LL(X) | Extra Length Output Cable |
| • | Reduced Stored Energy |
| • | Filament Power Supply |
| • | 12kW, 18kW Parallel Operation |
| • PN | Reversible Polarity |
| • EFR | External Fault Relay |

Table 1.1 SR Options

The options available are listed in Table 1.1. See Section 5 for more information on these options along with operating and set-up instructions. With few exceptions, these options and modifications can be retrofitted to your power supply at the factory in a short time. For price and retrofit arrangements, contact Spellman's Sales Department.

1.5 Interpreting the Model Number:

The model number of the power supply describes its capabilities. After the series name is:

- (1) the maximum voltage (in kV)
- (2) the polarity of the unit – positive (P), negative (N), or reversible (PN)
- (3) the maximum output (in kilowatts)

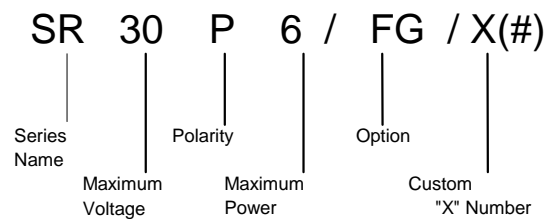

- (4) the option codes for all options that are included.
- Custom units have an X number after the option codes.

Chapter 2

Inspection and Installation

Initial inspection and preliminary checkout procedures are recommended. For safe operation, please follow the step-by-step procedures described in Chapter 3, Operating Instructions.

2.1 Initial Inspection

Inspect the package exterior for evidence of damage due to handling in transit. Notify the carrier and Spellman immediately if damage is evident. Do not destroy or remove any of the packing material used in a damaged shipment.

After unpacking, inspect the panel and chassis for visible damage.

Fill out and mail the Warranty Registration card accompanying the unit. Standard Spellman SR high voltage power supplies and components are

covered by warranty. Custom and special order models (with an X suffix in the model number) are also covered by warranty.

2.2 Mechanical Installation

Units in the SR series have front panel holes for standard EIA rack mounting. The rack must allow rear access for cable connections. Units are fully enclosed and are suitable for bench or tabletop operation. Standard unit dimensions are shown in Figure 2.1. It is strongly recommended to support the chassis by guides or slides. Rotating slides are available for ease of servicing of the top and bottom assemblies (SL option).

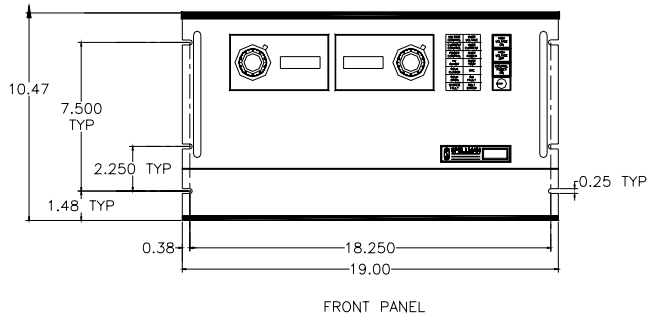

FRONT PANEL

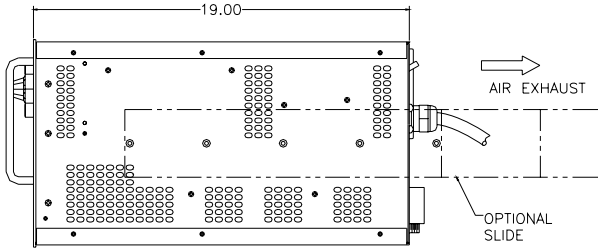

STANDARD CHASSIS

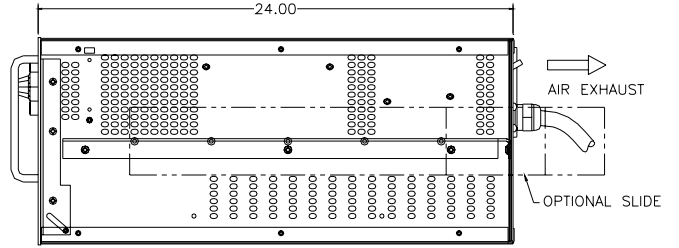

EXTENDED CHASSIS

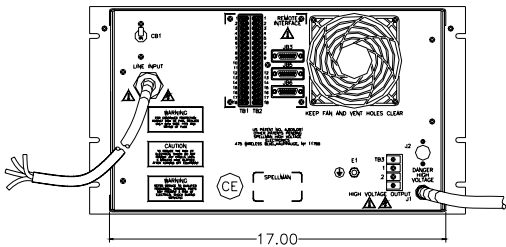

STANDARD CHASSIS
REAR PANEL

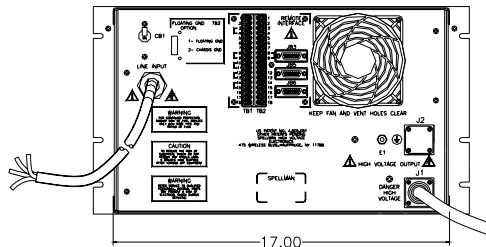

EXTENDED CHASSIS
REAR PANEL

Figure 2.1 DIMENSIONS

Chapter 3

Operating Instructions

3.1 Operation

WARNING

THIS EQUIPMENT GENERATES DANGEROUS VOLTAGES THAT MAY BE FATAL. PROPER GROUNDING OF ALL HIGH VOLTAGE EQUIPMENT IS ESSENTIAL.

WARNING:

BEFORE CONNECTING THE POWER SUPPLY TO THE AC LINE, FOLLOW THIS STEP-BY-STEP PROCEDURE. DO NOT CONNECT THE POWER SUPPLY TO THE AC LINE UNTIL STEP 'H' IS REACHED. FAILURE TO FOLLOW THESE PROCEDURES MAY VOID THE WARRANTY.

- A) Insure that the CONTROL POWER ON switch is in the OFF position (switch bezel out).
- B) Check the input voltage rating on the nameplate of the supply and make certain that this is the rating of the available power source. Spellman SR units operate on 208V AC three phase unless ordered with a different input voltage.
- C) **PROPER GROUNDING TECHNIQUE:** The chassis of high voltage power supplies must be grounded, preferably to a water system ground using copper pipe or other earth ground using the connection terminal at the rear of the unit.. See Figure 3.1 for a typical operating setup.

The return line from the load should be connected to the terminal on the rear of the power supply. Using a separate external ground at the load is not recommended.

A four-wire cable is provided for connecting to the AC supply. The BROWN, BLACK and BLUE wires are the three phase input. The GREEN/YELLOW wire is for chassis safety ground connection.

- D) Attach the output cable to the load.
- E) Plug the high-voltage output cable provided with the unit into the rear of the supply and hand tighten the knurled collar.
- F) **Options Note:** See section 5 for hook up and operating instructions for the options on your unit. Custom models may also require set up changes.
- G) For initial turn-on, rotate the KILOVOLT control fully counter-clockwise to the zero voltage position.
- H) The input power cable may now be connected to the AC power line.
- I) Depress the CONTROL POWER ON switch. The light inside the switch should light up. The unit is now in the HIGH VOLTAGE OFF mode. The HIGH VOLTAGE OFF light should be lit.

J) Depress and hold the HIGH VOLTAGE OFF switch. The front panel meters will now read the preset value of the KILOVOLT control dial and the MILLAMPERES control dial. To preset the desired level of the current and voltage during operation, hold the HIGH VOLTAGE OFF switch and rotate the appropriate control dial while noting its corresponding meter reading. Release the HIGH VOLTAGE OFF switch.

NOTE: No actual output is being produced at this stage.

K) Depress the HIGH VOLTAGE ON switch. The light inside the switch should light up and the output will slow start to the preset level output voltage and/or output current.

Note: The SR series is equipped with a slow start circuit that ramps the output up to its maximum setting in approximately 6 seconds after the HIGH VOLTAGE ON switch is depressed.

L) To terminate the generation of output power, depress the HIGH VOLTAGE OFF switch. In the HIGH VOLTAGE OFF mode the power supply's fault and interface circuits are still active.

M) To turn off the power supply, depress the CONTROL POWER ON switch to release the switch bezel to the out position.

NOTE: If a power supply fault, or system monitoring fault occurs, the power supply will revert to the POWER DOWN mode. In this mode the output power will be turned off. The CONTROL POWER ON lamp will flash indicating a SYSTEM FAULT. To reset the SYSTEM FAULT toggle the CONTROL POWER ON switch.

WARNING

**AFTER TURNOFF, DO NOT HANDLE THE LOAD UNTIL THE CAPACITANCE HAS BEEN DISCHARGED!
LOAD CAPACITANCE MAY BE DISCHARGED BY SHORTING TO GROUND.**

WARNING

THE VOLTMETER ON THE POWER SUPPLY FRONT PANEL DOES NOT READ THE OUTPUT VOLTAGE WHEN THE POWER IS TURNED OFF, EVEN IF A CHARGE STILL EXISTS ON THE LOAD.

CAUTION

ALWAYS OPERATE THE UNIT WITH THE COVER ON.

A fan maintains safe operating temperature in the power supply by drawing air over the circuit components. The cover must be on in order to direct the air flow over the areas that need cooling. In operation, the unit must be placed so that the air intake and the fan exhaust are clear of any obstructions that might impede the flow of air.

3.2 Standard Features

A note on remote interface circuitry and remote signal grounding. Whenever possible, electrical isolation should be provided when interfacing with any high voltage power supply. For power control signals such as POWER ON/OFF, EXTERNAL INTERLOCK, HIGH VOLTAGE OFF and HIGH VOLTAGE ON isolated relay contacts should be used. For status signals and control signals such as HIGH VOLTAGE ON, HIGH VOLTAGE OFF, EXTERNAL INHIBIT, etc. Opto-isolation should be used. If possible, analog programming and monitoring signals should be isolated via analog isolation amplifiers. Spellman application engineers are available to assist in interface circuitry design. All interface cables should be properly shielded. All power supply signals should be referenced to the power supplies signal ground on the rear terminal block TB1-1.

REMOTE PROGRAMMING: Allows remote adjustment of the output voltage and current via an external voltage source. (Output power is also remotely controllable with the CPC and APT options). In local control (front panel control), jumpers are installed on the terminal block TB1 in the rear of the chassis between TB1-10 and TB1-11 for voltage control and between JB1-8 and JB1-9 for current control. (Jumpers are installed between TB2-8 and TB2-9 for power control).

For remote programming, the jumpers are removed and a positive voltage source, from 0 to 10 volts, is applied to the appropriate terminals. Programming signals should be referenced to TB1-1, signal ground. By adjusting the voltage source from 0 volts (zero output) to 10 volts (full rated output) the desired output can be selected. See Figure 3.2A for wiring diagram and specifications.

An alternate method of controlling the output remotely is by using external resistance such as a potentiometer or a resistor network. For remote control the jumpers are removed and the desired resistor configuration is installed. See Figure 3.2B for wiring diagram.

REMOTE MONITOR: Test points are made available on the rear of the chassis for monitoring the voltage and current output. (Output power monitor is included with the CPC and APT option). The test points are always positive regardless of the output polarity, where zero (0) to ten (10) volts equals 0-100% of output $\pm 0.5\%$. Test points have an output impedance of 1k ohms. See Figure 3.3 for test point designation.

REMOTE CONTROL: Remote control of the POWER ON, HIGH VOLTAGE ON and HIGH VOLTAGE OFF can be accomplished via the rear panel interface. The POWER ON control is an on-off toggle contact. HIGH VOLTAGE OFF and HIGH VOLTAGE ON are controlled by momentary normally closed normally open contacts, respectively. See Figure 3.4 for recommended interface.

EXTERNAL INHIBIT: Allows the user to inhibit the power supply output without switching the HIGH VOLTAGE OFF control. This circuit can be used to generate fast slewing output waveforms or control high voltage generation as in Laser and Capacitor discharge applications. The maximum inhibit rate should not exceed 5Hz. Consult factory for higher repetition rates or high pulse load applications. See Figure 3.5 for the recommended interface circuit.

WARNING

IT IS EXTREMELY DANGEROUS TO USE THIS CIRCUIT TO INHIBIT HIGH VOLTAGE GENERATION FOR THE PURPOSE OF SERVICING OR APPROACHING ANY AREA OF LOAD CONSIDERED UNSAFE DURING NORMAL USE

EXTERNAL INTERLOCK: Interlock connections are provided on the terminal block TB1, terminals #3 and #4, on the rear of the chassis for connection to a safety switch. The unit will not operate unless the interlock circuit is closed. If the interlock is not being used, the jumper installed on the terminals before shipping *must* be in place. If the jumper is missing, or there is an open between the interlock terminals the unit's high voltage inverter will be disabled. During high voltage operation, opening the interlock circuit will cause the unit to revert to the HIGH VOLTAGE OFF mode. Subsequent closing of the interlock circuit will NOT return the unit to HIGH VOLTAGE ON mode, this must be accomplished by depressing the HIGH VOLTAGE ON switch. See Figure 3.6 for the recommended interface circuit.

ARC DETECT / ARC QUENCH ARC COUNT: The ARC DETECT circuit senses dynamic arcing or discharge conditions present at the output load. If an arc occurs, the

output is inhibited for one second. After the one-second period, the output is ramped up to the previous set level. This ramp is based on the standard six-second slow start feature. The ARC DETECT ramp circuit may be disabled by removing CR32 on the System Control PWB. The ARC QUENCH circuit may be disabled by removing CR40 of the System Control PWB. Caution should be observed if these features are disabled. Discharge rates of greater than 1 Hz may cause excessive power dissipation in the power supply's output limiting resistors.

The ARC COUNT feature will allow the user to program the ARC fault parameters. The ARC indicator on the front panel will illuminate for approximately one second after each arc has occurred. The HV INHIBIT indicator will also illuminate for one second indicating that the output is being inhibited. The power supply can be programmed to trip to the POWER DOWN mode if an arc occurs. The standard feature is programmed to trip the power supply if 8 arcs occur within a twenty second period. Details for programming the ARC COUNT feature are provided on schematics 440371-001 at the end of this manual.

REMOTE HIGH VOLTAGE ON & REMOTE HIGH VOLTAGE OFF: Signals are provided for remote monitoring of the HIGH VOLTAGE ON/OFF status. See Figure 3.7 for recommended interface.

It is recommended to connect the load return directly to the E1 ground stud located on the rear of the high voltage power supply.

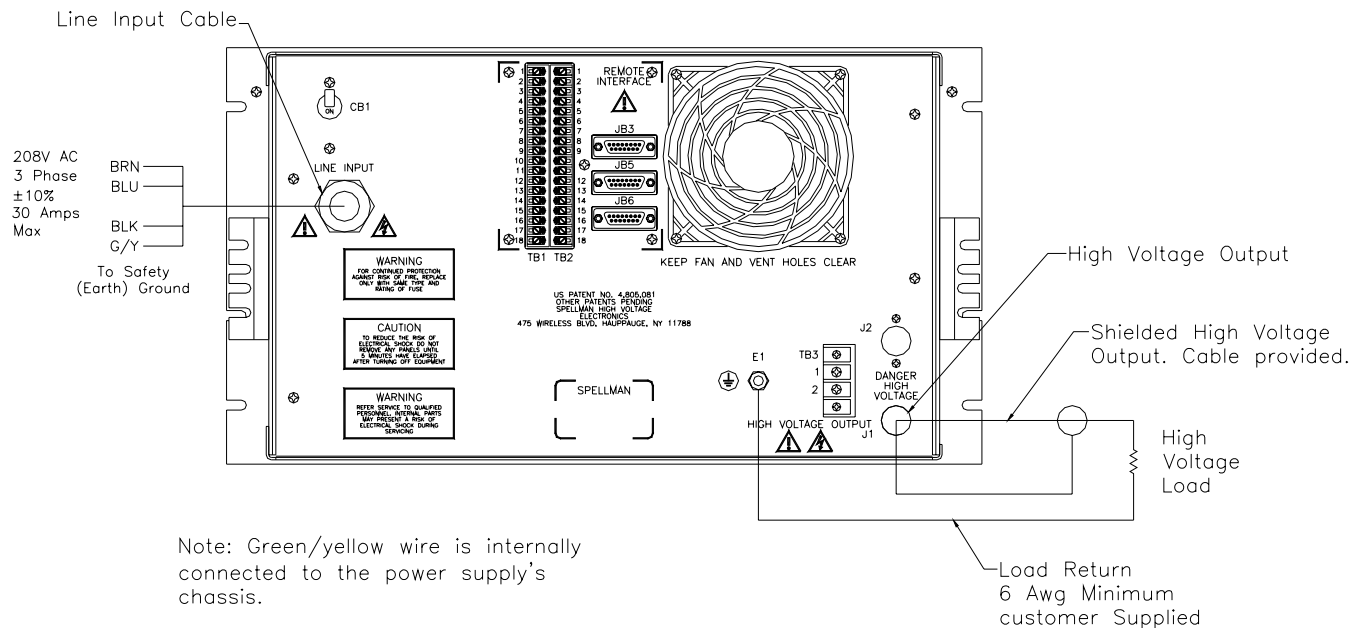

Figure 3.1 Typical Operating Setup SR

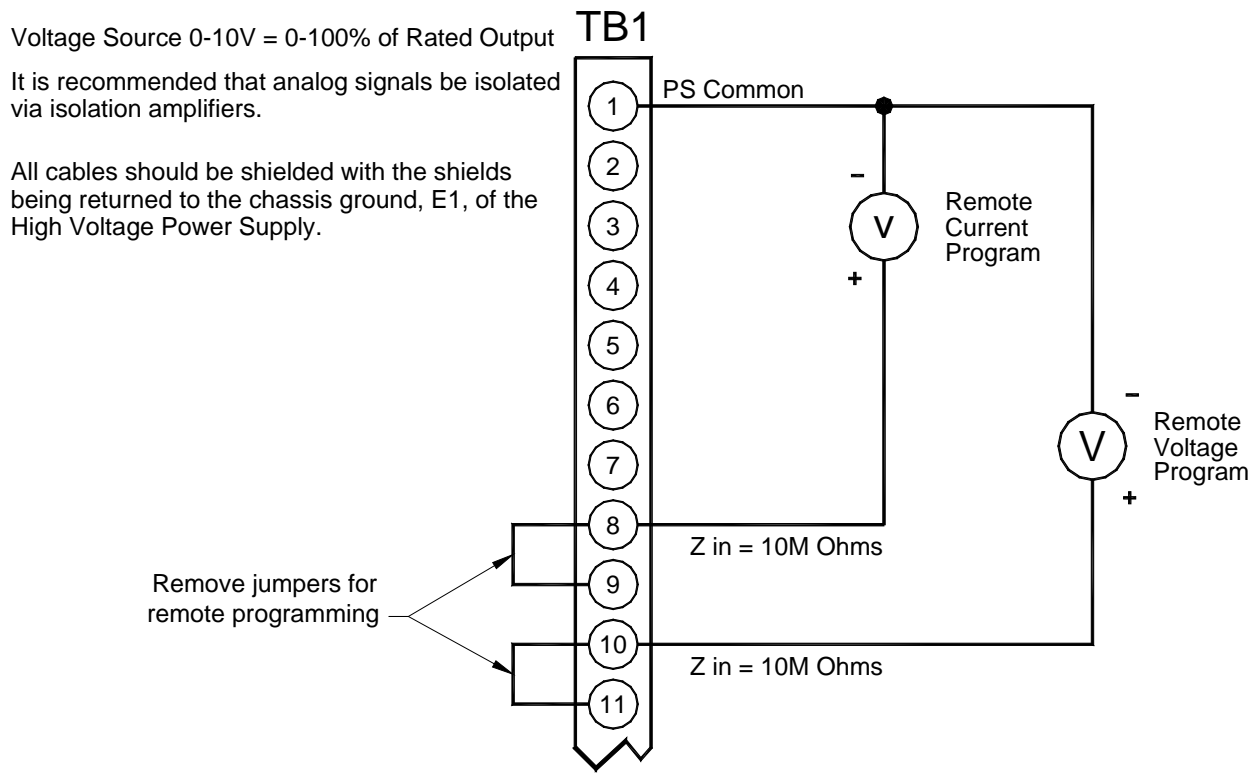

Figure 3.2A Wiring Diagram for Remote Programming via Voltage Source

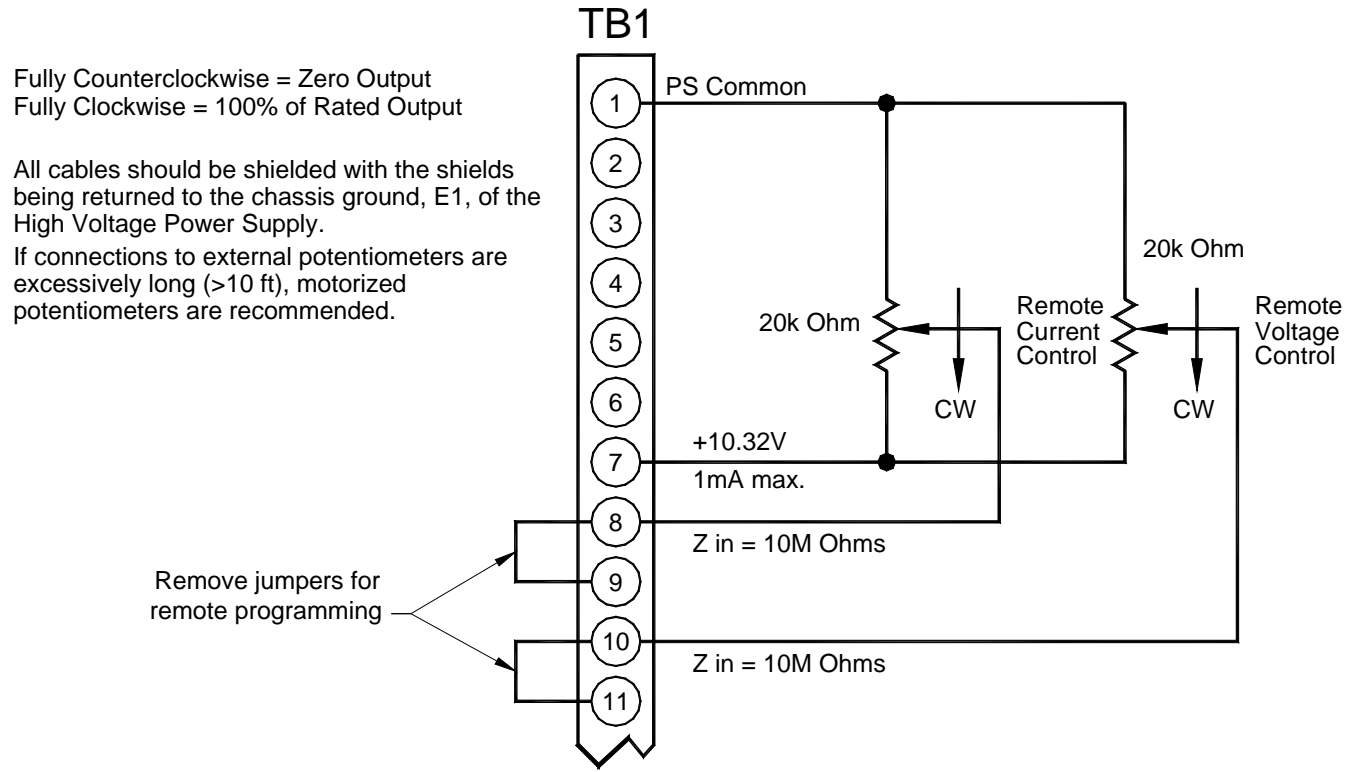

Figure 3.2B Wiring Diagram for Remote Programming via External Resistance

It is recommended that analog signals be isolated via isolation amplifiers.

All cables should be shielded with the shields being returned to the chassis ground, E1, of the High Voltage Power Supply.

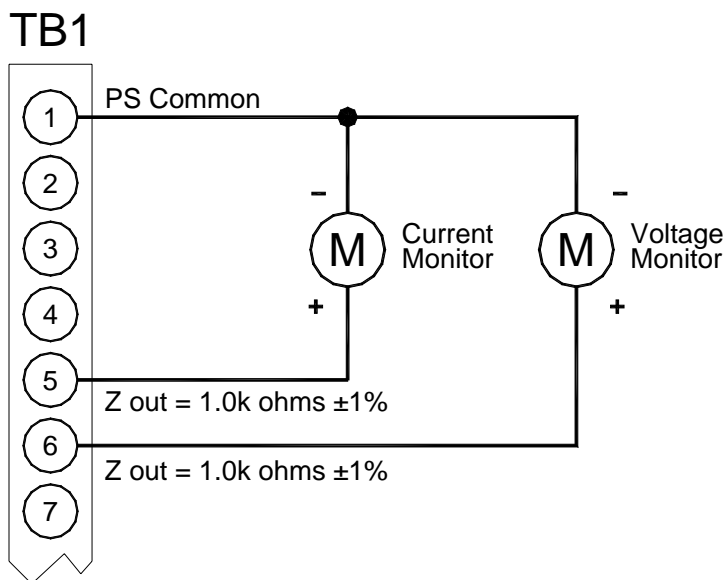

Figure 3.3 Remote Monitor Test Point Designations

It is recommended to use relay contacts for S1, S2 and S3. Relays should be located as close as possible to the high voltage power supply. Coils should be driven from isolated sources. Signals are at ~24V, 100mA max, and are only to be used for contact closure.

S1 must be closed to enable HIGH VOLTAGE ON. Momentary closure of S2 will enable HIGH VOLTAGE ON.

Opening S1 will disable HIGH VOLTAGE ON and switch the unit to the HIGH VOLTAGE OFF mode

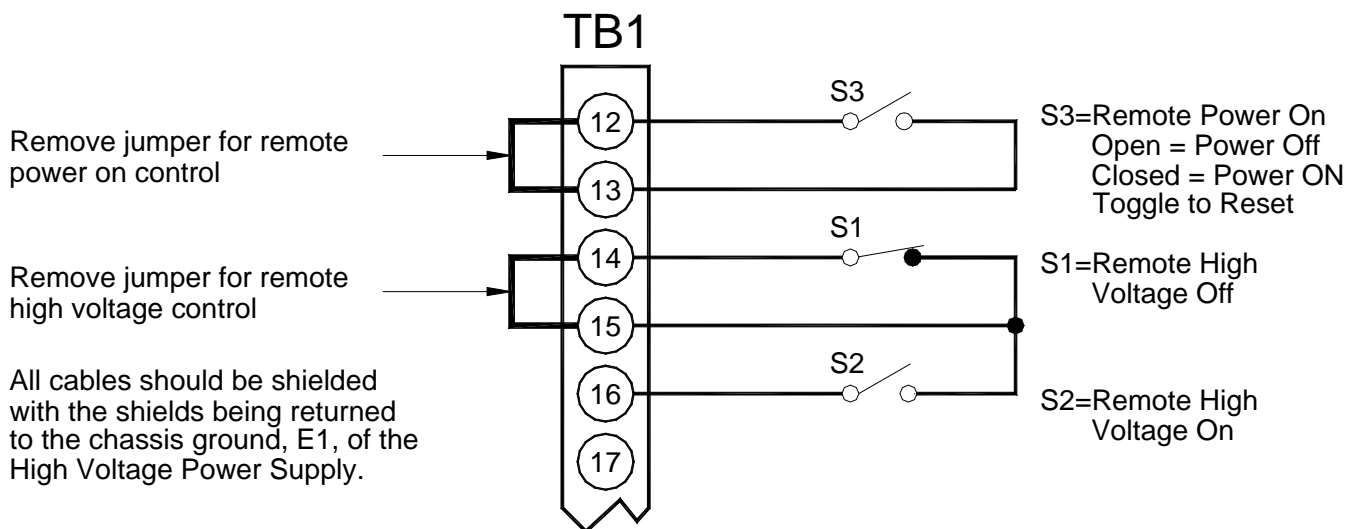

Figure 3.4 Remote Control of Power ON, High Voltage ON and High Voltage OFF

Opto-coupler should be located as close as possible to the power supply.

All cables should be shielded with the shields being returned to chassis ground, E1, of the High Voltage Power Supply.

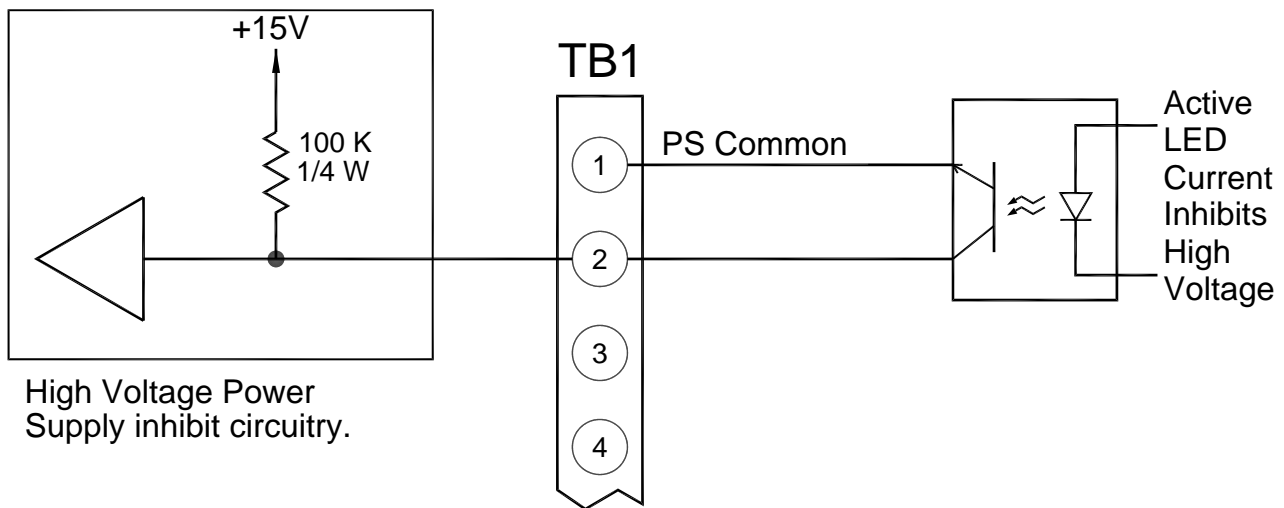
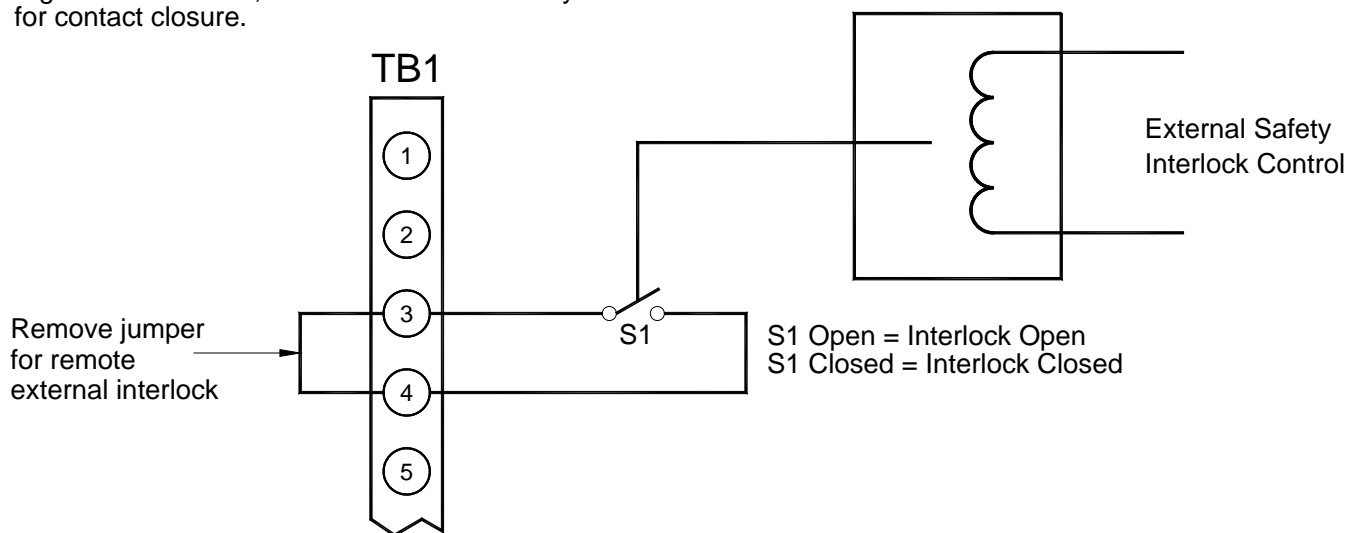

Figure 3.5 External Inhibit Interface Circuit

It is recommended to use relay contacts for S1. The relay should be located as close as possible to the power supply. Signals are ~24Vdc, 100mA max and are only to be used for contact closure.



All cables should be shielded with the shields being returned to chassis ground, E1, of the High Voltage Power Supply.

Figure 3.6 External Interlock Interface Circuit

24Vdc lamps or relay coils may replace opto-couplers.
 Opto-couplers, lamps or relays should be located as close
 as possible to the high voltage power supply.
 All cables should be shielded with the shields being returned
 to chassis ground, E1, of the High Voltage Power Supply.

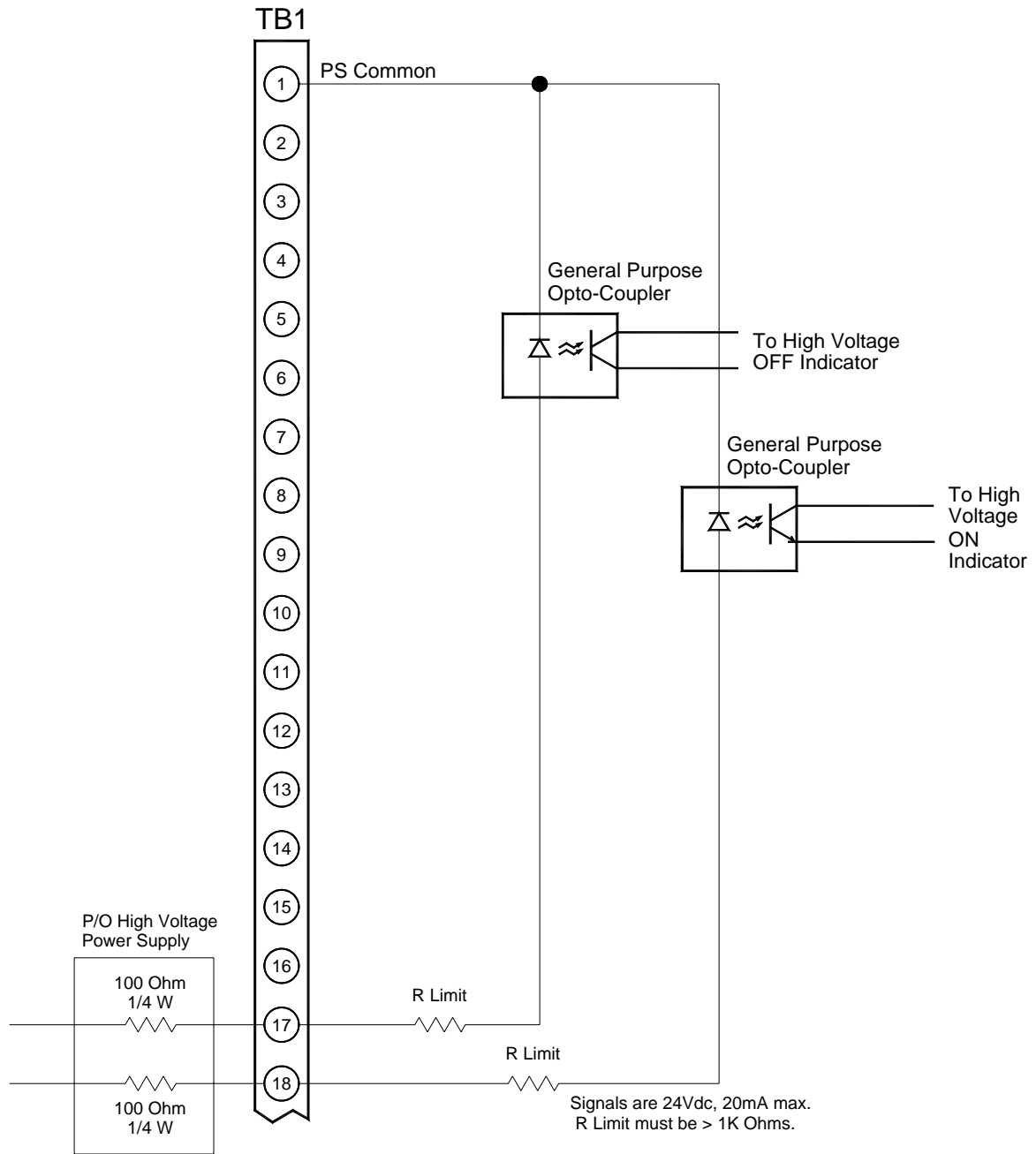

Figure 3.7 Remote High Voltage ON and Remote High Voltage OFF Indicator

Chapter 4

Principles of Operation

The SR series of high voltage power supplies utilizes sophisticated power conversion technology. A variety of analog, digital and power conversion techniques are used throughout. The intention of the Principles of Operation is to introduce the basic function blocks that comprise the SR power supply. For details on a specific circuit, consult Spellman's Engineering Department.

See Table 4.1 for a list of the main assemblies found in a typical SR power supply.

* Due to the many variations within the SR series, drawing numbers may differ from unit to unit.

The SR power supply is basically an AC to DC converter. Within the power supply, conversions of AC to DC, then high frequency AC, then to high voltage DC take place. By reviewing further the sub-assemblies, a basic understanding of the process can be gained.

4.1 Chassis

The SR is a compact, high efficiency, high voltage power supply. The power supply can supply up six kilowatts of DC power. (Output power capability may be higher or lower depending upon model ordered). Output voltages of up to 120kV can be generated.

WARNING

THE ENERGY LEVELS USED AND GENERATED BY THE POWER SUPPLY CAN BE LETHAL! DO NOT ATTEMPT TO OPERATE THE POWER SUPPLY UNLESS THE USER HAS A SUFFICIENT KNOWLEDGE OF THE DANGERS AND HAZARDS OF WORKING WITH HIGH VOLTAGE. DO NOT ATTEMPT TO APPROACH OR TOUCH ANY INTERNAL OR EXTERNAL CIRCUITS OR COMPONENTS THAT ARE CONNECTED OR HAVE BEEN CONNECTED TO THE POWER SUPPLY. BE CERTAIN TO DISCHARGE ANY STORED ENERGY THAT MAY BE PRESENT BEFORE AND AFTER THE POWER SUPPLY IS USED. CONSULT IEEE RECOMMENDED PRACTICES FOR SAFETY IN HIGH VOLTAGE TESTING #510-1983.

4.2 Line Rectification and Filtering

Basic single phase or three phase rectification provides the DC voltage for the high frequency inverter.

The FILTER CHOKE ASSEMBLY, FILTER CAP. ASSEMBLY and main chassis components comprise the circuits for line voltage rectification. The line input SR MANUAL

voltage can vary from 180 up to 264 volts within the SR series. In general, the following variations can be ordered:

200Vac $\pm 10\%$, 50/60Hz, 400Hz, three phase or single phase.

208Vac $\pm 10\%$, 50/60Hz, 400Hz, three phase or single phase.

220Vac $\pm 10\%$, 50/60Hz, 400Hz, three phase or single phase.

240Vac $\pm 10\%$, 50/60Hz, three phase.

Other input voltages can be accommodated. If the user is unsure which input voltage option is supplied, check the serial tag on the rear of the power supply or consult Spellman's Sales Department

Circuit protection is provided by CB1 (SYSTEM BLOCK DIAGRAM CHASSIS SR SCHEMATIC). CB1 is a fast acting magnetic trip type circuit breaker. The line input is connected directly to the line side of CB1. The load side of CB1 is connected to K1, (FILTER CHOKE ASSEMBLY SR). K1 is a definite purpose contactor. K1 provides fail-safe type disconnection of the line voltage to power supply rectification circuits. K1 coil is controlled by a variety of circuit conditions, which will be described later on. The load side of CB1 is also connected to T1 via F1. F1 is a 1 amp fuse, which provides primary and secondary circuit protection for circuits supplied by T1. T1 is a step-down type line transformer. T1 provides voltage for housekeeping and control circuit power.

WARNING

LINE VOLTAGE IS PRESENT WHENEVER THE POWER SUPPLY IS CONNECTED TO EXTERNAL LINE VOLTAGES. BE SURE TO DISCONNECT THE LINE CORD BEFORE OPENING THE UNIT. ALLOW 5 MINUTES FOR INTERNAL CAPACITANCE TO DISCHARGE BEFORE REMOVING ANY COVER.

| ASSEMBLY TITLE | ASSEMBLY DRAWING NO. | SCHEMATIC DRAWING NO. |
|--------------------------|----------------------|-----------------------|
| SR Chassis | 403552-TAB | 440374-008 |
| Filter Choke Assembly | 403477-001 | 340198-001 |
| Filter Cap. Assembly | 403476-001 | 440376-001 |
| Rail Cap. Assembly | 403460-001 | 240048-001 |
| Inverter Assembly | 403443-002 | 440369-002 |
| System Control PWB | 403445-001 | 440371-001 |
| Inverter Drive PWB | 405442-001 | 440870-001 |
| High Voltage Assembly | 403514-TAB | 440390-TAB |
| Front Panel Assembly | 403446-TAB | 440372-001 |
| Rear Panel Interface PWB | 403447-001 | 440373-001 |

Table 4.1 List of Main Assemblies

When K1 is energized, voltage is applied to CR1. CR1 is an isolated diode power module. It contains the rectifier diodes used for line voltage rectification. K1 voltage also supplies power to fans used throughout the chassis for cooling purposes. The output of CR1 is connected to an LC (C for single phase) filter. C1 and C2, (FILTER CAP. ASSEMBLY), are aluminum electrolytic capacitors. They are the capacitors used in the LC filter. Capacitors C1 and C2 are initially charged through a charging resistor. This resistor is located on the AC PWR/CONTROL PWB.

Approximately 1 second after K1 contactor closure occurs, a relay is energized to short the charging resistor. This relay is K1 on the FILTER CAP. ASSEMBLY. The DC voltage on C1 and C2 is approximately 1.4 times the input voltage. This DC voltage is supplied to the high frequency inverter through L1, L2, L3 and L4. These inductors provide isolation for the high frequency inverter if a cross conduction or "shoot thru" occurs. Hence, L1 thru L4 are termed shoot thru chokes.

The AC PWR/CONTROL PWB provides a variety of control and diagnostic functions. R1, R2 and R3 are the charging resistors previously described. These resistors limit the initial charging current for the capacitors used for line rectification. U1 and its associated circuitry monitor the voltage across the charging resistor. If any abnormal conditions appear, circuitry will shutdown the power supply. Typically a SYSTEM FAULT indication will appear on the front panel if an error in the charging circuits has occurred. DS4 (AC FAULT), located on the SYSTEM CONTRPL PWB, will also indicate a fault condition. U2 and its associated circuitry monitor the rectified DC voltage. If an abnormal condition is present,

the same fault indication will be generated. R6 and R7 are bleeder resistors, which are used to discharge the filter capacitors. DS1 provides visual indication when DC voltage is present. This indicator should not be relied on for confirming the presence or absence of the DC voltage. Resistors R4, R5, R8 and R9, along with diodes CR1, CR2, CR3 and CR4 provide clamping for the shoot thru inductors described above. Integrated circuits U3, U4 and U5 provide logic for AC fault conditions, contactor control and relay control.

The shoot thru inductors are connected to the RAIL CAPACITOR ASSEMBLY. These capacitors are high frequency, low loss type. Capacitors C1 through C8 provide the energy storage for the high frequency inverter. The DC voltage is applied to the high frequency inverter, (INVERTER ASSEMBLY SR).

4.3 Inverter

The inverter is a series resonant, series loaded topology. A proprietary control scheme is used for regulating the power generated from the inverter. L1, L2, L3 and L4 are the resonating inductors. The RESONANT CAP. ASSEMBLY, A1, comprise the resonating capacitors. Q1 and Q2 are high speed IGBT's. These devices provide high frequency switching to control the resonant current flow. The typical resonant operating period is approximately 20uSeconds. The gate control for the switching devices is provided by the INVERTER DRIVE PWB. VC01 and VC02 signals are generated by the SYSTEM CONTROL PWB.

The INVERTER DRIVE PWB provides the required gate pulse width and phase control. The INVERTER DRIVE PWB also provides circuitry for sensing shoot thru conditions. U7–U10 and its associated circuitry provide pulse by pulse current limiting to a defective switching device and provides the high current pulse requirements for the switching device gates. T1 provides line voltage isolation.

4.4 High Voltage Transformer

The output of the High Frequency Resonant Inverter is connected to the primary of the High Voltage Transformer. The High Voltage Transformer is a step-up type. Typically secondary voltages are in the range of 1kV to 4.5kV depending upon output voltage ratings.

4.5 High Voltage Assembly

The High Voltage Assembly will vary depending upon the model ordered. The circuitry typically consists of a full wave, full bridge, or full wave doubler for voltage outputs in the range of 1KV to 6KV. The higher voltage ranges utilize various parallel, series arrangements of a full wave voltage doubler. For example, the 8KV output is obtained by connecting a number of full wave voltage doublers in parallel. The 120KV output is obtained by connecting a number of full wave voltage doublers in series.

Output filtering is typically provided by an L-C type filter. Voltage feedback for regulation and monitoring is provided by a high bandwidth resistive/capacitive divider. Current feedback for regulation and monitoring is provided by a sense resistor connected at the low voltage end of the High Voltage Rectifier.

4.6 System Control PWB

The majority of control circuits for power supply controls are located on the SYSTEM CONTROL PWB. For trouble shooting and testing purposes, this board can be easily accessed by removing the six #10 screws, located on the side panels near the front panel. The front panel will hinge down allowing for easy access to the SYSTEM CONTROL PWB.

+24VDC, -24VDC, +15VDC, -15VDC, and +10VDC are generated on the SYSTEM CONTROL PWB. High Voltage On/Off control is accomplished by K2, and its associated circuitry. Interlock control is provided by K3.

System shutdown is accomplished by a logic low at U5 Pin 3. K1 provides control power On/Off switching.

Voltage feedback from the high voltage divider is sent to U6. Gain adjust is provided by R22 (KVDC CAL). Bandwidth adjustment is provided by R18 (KV AC CAL). The KV feedback signal is sent to the front panel DVM and to the REAR PANEL INTERFACE PWB for remote monitoring. K4 provides switching between feedback and program signal for the front panel DVM's. This allows the user to preset the desired output before energizing high voltage.

Program voltages are typically ramped up to set level by the slow start circuits of U11.

Arc sense circuits T1, Q7, U5 and U9 provide sensing, quench and indication of arc conditions. Consult operation manual for a detailed description of the arc sense control.

Current feedback from the high voltage rectifier is sent to sense resistors R227 thru R232. U12 provides gain adjustment (mA CAL).

An overvoltage protection divider located in the HIGH VOLTAGE ASSEMBLY provides protection in the unlikely event of a main control loop failure. U15 provides gain adjustments for the overvoltage protection (OVP) control.

U17, U18 and U19 circuits provide visual indication of the control mode, which is in operation. These signals are sent to the FRONT PANEL ASSEMBLY for front panel status indication.

The series resonant control circuitry consists of a voltage frequency and a voltage to phase converter. U23 generates all frequency and phase control signals. U24, U26 and U22 provide specific phase control functions for the VCO1 and VCO2 signals.

Power supply inhibit circuits are provided by U16 and U28. Signals from the AC PWR/CONTROL PWB, the INVERTER DRIVE PWB, and the REAR PANEL INTERFACE PWB are used for inhibit control of the power supply.

System Fault Control and Indication is provided by U30, U21, U31, U29, U32 thru U36 and associated circuitry. Diagnostic signals are latched and sent to the FRONT PANEL ASSEMBLY for status indication

4.7 Front Panel Assembly

Front Panel controls, meters, and status indications are connected to the FRONT PANEL PWB. The FRONT PANEL PWB interfaces directly to the SYSTEM CONTROL PWB.

4.8 Rear Panel Interface PWB

Signals going to and from the remote interface are sent through the REAR PANEL INTERFACE PWB. The

REAR PANEL INTERFACE PWB connects directly to the SYSTEM CONTROL PWB.

4.9 Options

Due to the many variations of models and options provided in the SR series, details of actual circuits used may differ slightly from above descriptions. Consult Spellman's Engineering Department for questions regarding the principles of operations for the SR series.

Chapter 5

OPTIONS

The options available for this power supply are described in this section. Interface diagrams are shown where required. Options are specified by including the option code in the model number as described in Section 1.5.

5.1 Adjustable Overload Trip

AOL

The overload trip protection feature rapidly shuts down the high voltage output when the load current exceeds the limit set by the current control dial on the front panel. A fast acting circuit inhibits the generation of high voltage and reverts the unit to POWER DOWN mode, illuminating the OVER CURRENT indicator. When adjustable overload trip is provided, it replaces the standard current regulation feature.

5.2 220V AC Single Phase Input

220

SR power supplies with the 220 V AC input option will operate from an input voltage of 220VAC rms $\pm 10\%$, 50-60Hz, single phase.

5.3 No Slow Start

NSS

The no slow start option causes the output voltage of the power supply to rise (within 50 msec) to the rated voltage upon depressing the HIGH VOLTAGE ON Switch.

5.4 Non-Standard Slow Start

SS(x)

The non-standard slow start option allows the gradual rise time of the output voltage to be different from the standard of six seconds. To order the option, place the time desired in seconds after the suffix letter; i.e. SS(10) denotes a 10 second rise time.

5.5 Extra Length Output Cable

LL(ft)

Standard output cable is 10' of shielded high voltage cable. Other lengths may be specified in multiples of 10 feet.

5.6 Slides

SL

Units can be supplied with slides that mount into a standard EIA 19" wide rack.

5.7 Remote Over Voltage Adjust

ROA

This option allows the remote adjustment of the Overvoltage Trip level. This may be accomplished with a voltage source or a resistor arrangement that is similar to the Remote Program Feature. See Figure 5.1 for recommended interface.

5.8 Remote Mode Indicators

RMI

Signals are provided for remote indication of the control mode status, voltage control, current control and power control. See Figure 5.2 for the recommended interface.

5.9 Floating Ground

FG

The floating ground option allows isolation of the power supply common from chassis ground. TB3 located on the rear panel provides connection to the power supply common circuit and to chassis ground. This signal can be used for a variety of applications. A typical application for FG is for connection of an external meter or circuit into the FG point. This circuit can monitor actual current flow at a low voltage level. See Figure 5.3 for typical connection to the floating ground terminal.

IMPORTANT

THE POWER SUPPLY COMMON MUST BE CONNECTED TO CHASSIS GROUND THROUGH A LOW IMPEDANCE CIRCUIT. THE POWER SUPPLY COMMON IS CLAMPED TO THE CHASSIS GROUND USING A POWER ZENER DIODE. THIS DIODE IS NOT INTENDED TO CLAMP UNDER CONTINUOUS OPERATION. ON HIGHER CURRENT UNITS THE POWER DISSIPATION CAN BE EXCESSIVE IF ALLOWED TO CLAMP. SCHEMATIC 340212-001 PROVIDES ADDITIONAL INFORMATION ON THE FG OPTION.

It is recommended that analog signals be isolated via isolation amplifiers. If connections to external potentiometers are excessively long (>10 ft), motorized potentiometers are recommended.

All cables should be shielded with the shields being returned to chassis ground E1 of the high voltage power supply.

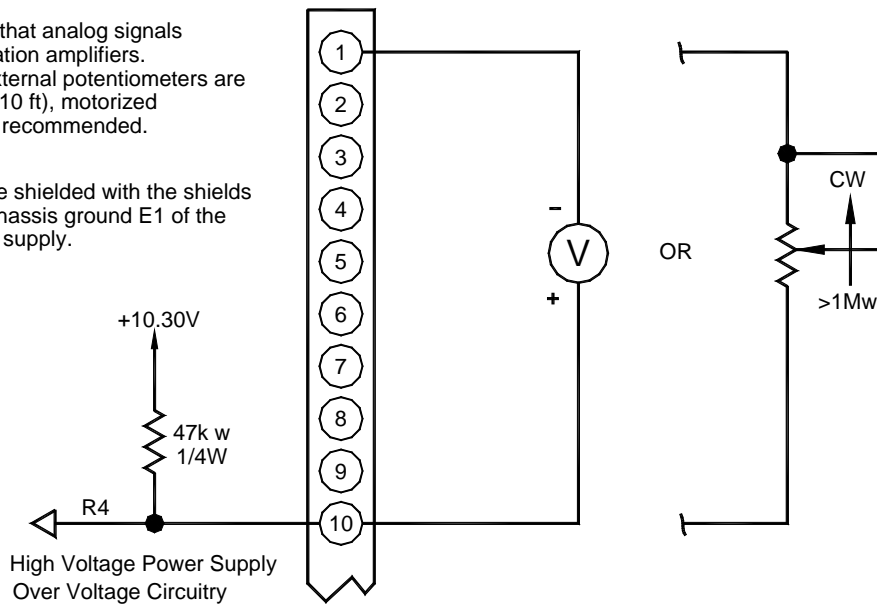

Figure 5.1 Remote Overvoltage Adjust Interface

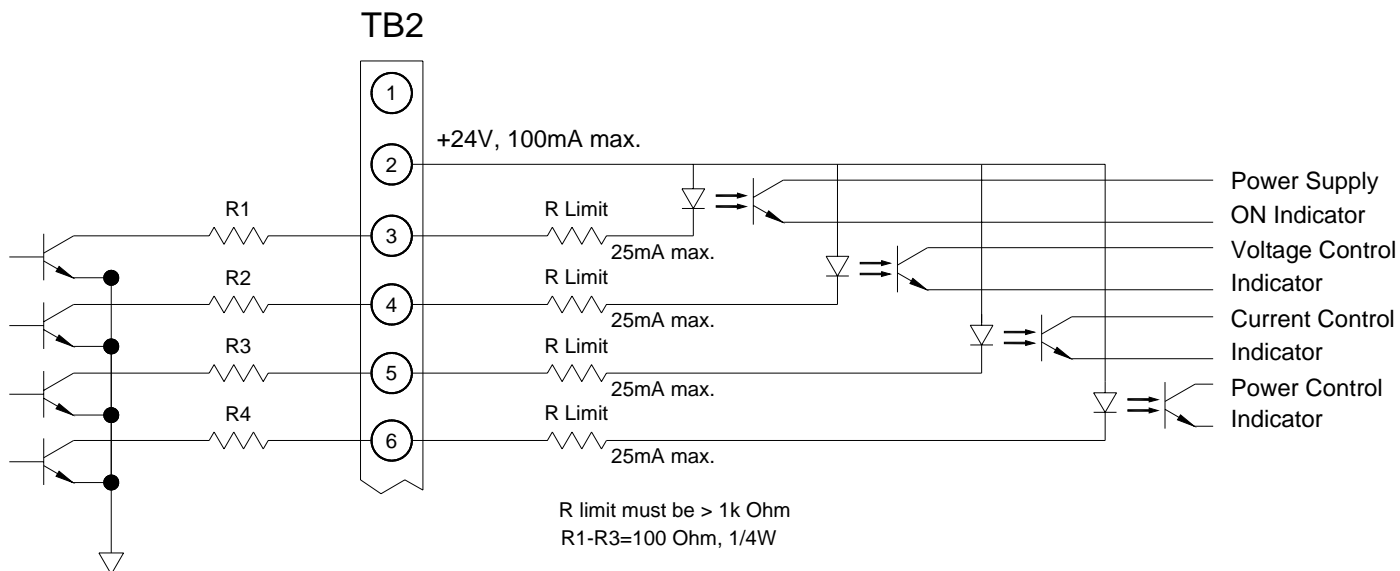
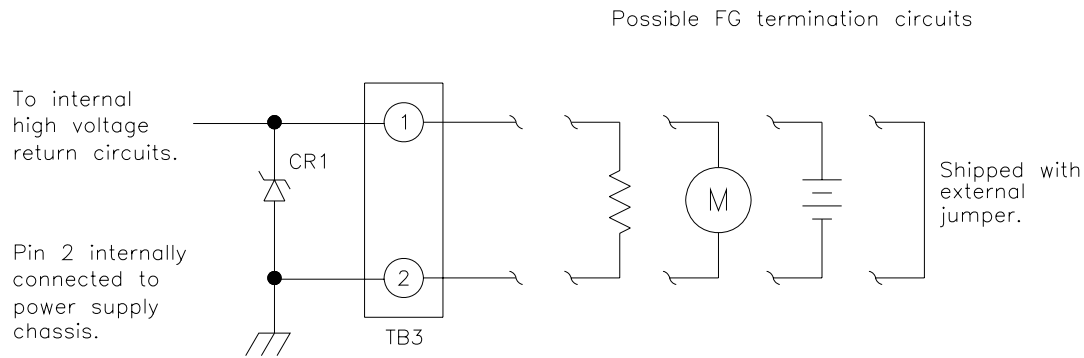

Figure 5.2 Remote Mode Indicators Interface



CR1— Polarity dependent on output voltage polarity. Zener voltage is 15V standard. Up to 50V is available. Consult factory.

IMPORTANT: Power dissipation in CR1 should not exceed 25W. This can be accomplished by keeping TB1–3 and TB3–2 voltage below Zener voltage. CR1 is for safety and transient protection only and is not designed for continuous clamping.

Figure 5.3 Floating Ground Interface Circuit

5.10 Adjustable Power Trip/Constant Power Control

The power control option allows monitoring and control of the power supply output power. The APT option allows the user to remotely adjust the power limit for the power supply. If the power limit is exceeded, the unit will shut down with an OVERPOWER fault. The CPC option allows power regulation via a remote program source. When the unit is in power regulation, the POWER CONTROL status indicator will be illuminated. See Figure 5.4 for remote interface.

5.11 Custom Designed Models X(#)

Units built to customer specifications are assigned an X number by the factory. If this unit is an X model, a specification control sheet is added at the end of this instructional manual.

Spellman welcomes the opportunity to tailor units to fit your requirements or to develop new products for your applications. Contact the Spellman Sales Department with your needs.

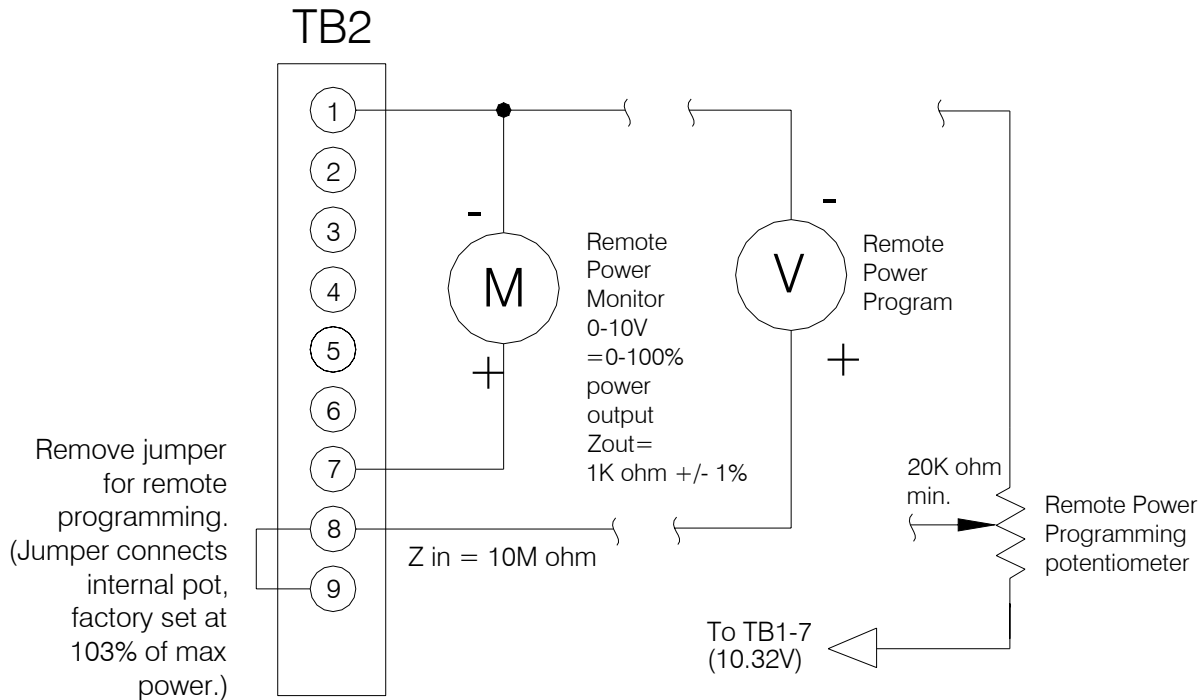

Figure 5.4 Adjustable Power Remote Interface

5.12 Parallel Option 12kW PO

Parallel Option 12kW systems are comprised of two separate rack mount chassis, the Master and Slave. The installation should be done as follows:

1. Install the racks per Installation Drawing Fig. 5.5.
2. Connect Signal Cable No. 302979-001 from Master JB5 to Slave JB5.
3. Connect Ground Cable No. 302085-009 from Master E1 to Slave E1.
4. Connect a ground cable (at least 6 AWG) to an external ground.

WARNING

HIGH VOLTAGE POWER SUPPLIES MUST ALWAYS BE GROUNDED. REFER TO OPERATING INSTRUCTIONS IN CHAPTER 3.

5. Connect H.V. Interconnect Cable from Master J1 to Slave J2.

| Output Voltage | Interconnect Cable |
|----------------|--------------------|
| 1kV to 6kV | 302039-015 |
| 8kV to 40kV | 302039-010 |
| 50kV to 60kV | 302039-011 |
| 70kV to 120kV | 403839-001 |

6. Connect H.V. output cable to Slave J1.

| Output Voltage | Interconnect Cable |
|----------------|--------------------|
| 1kV to 6kV | 100161-020 |
| 8kV to 40kV | 100161-012 |
| 50kV to 60kV | 100161-019 |
| 70kV to 120kV | 403625-002 |

NOTE: Before operating this system, refer to operating instructions in Chapter 3.

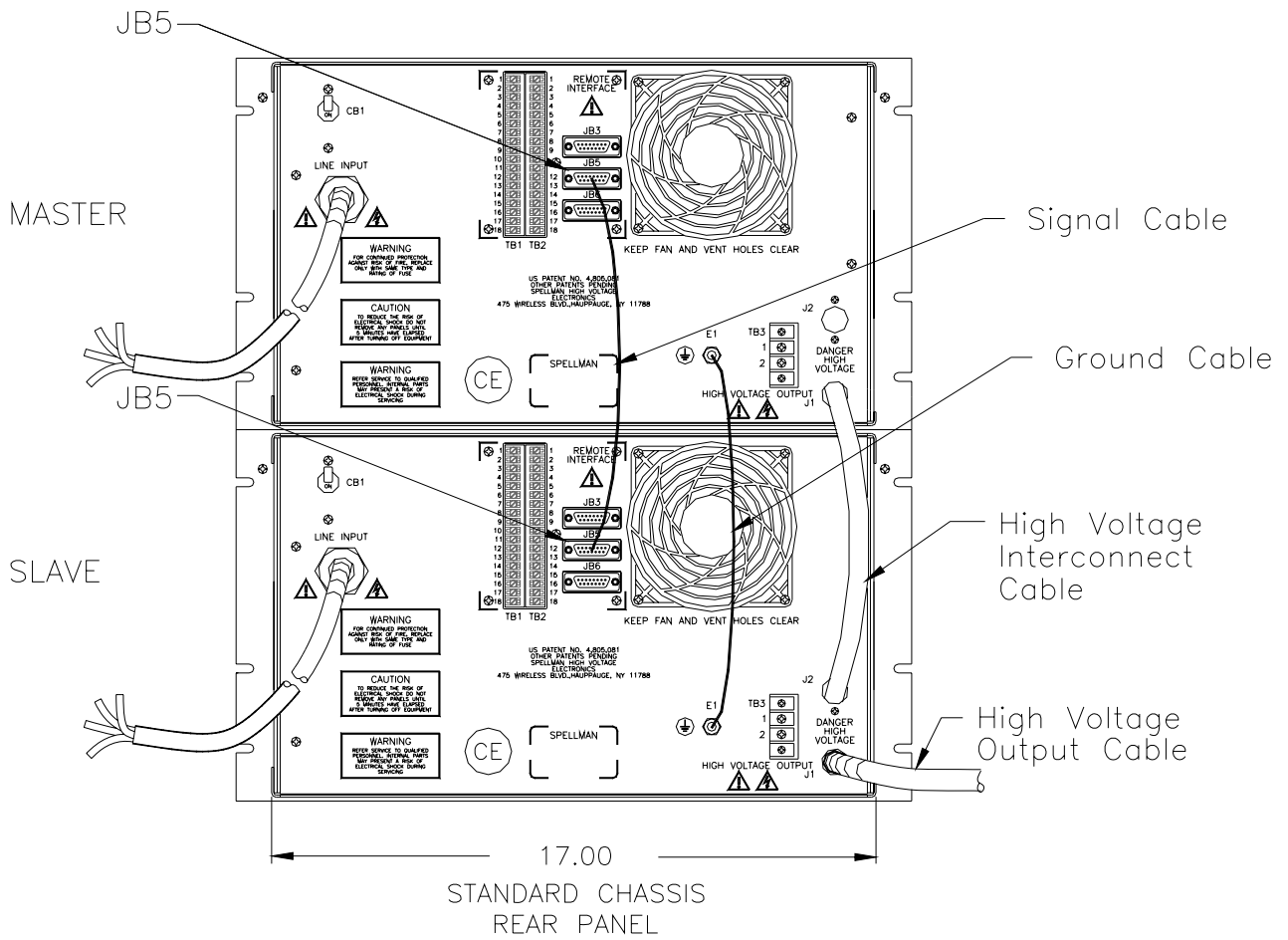

Figure 5.5 12kW Installation Drawing

5.13 Parallel Option (18kW) PO

Parallel Option 18kW systems are comprised of three separate rack mount chassis, the Master, Slave 1 and Slave 2. The installation should be done as follows:

1. Install the racks per Installation Drawing Fig. 5.6.
2. Connect Signal Cable No. 302979-001 from Master JB5 to Slave 1 JB5.
3. Connect Signal Cable No. 302979-002 from Master JB6 to Slave 2 JB6.
4. Connect Ground Cable No. 302085-009 from Master E1 to Slave 1 E1.
5. Connect Ground Cable No. 302085-009 from Slave 1 E1 to Slave 2 E1.
6. Connect a ground cable (at least 6 AWG) to an external ground.

WARNING

**HIGH VOLTAGE POWER SUPPLIES
MUST ALWAYS BE GROUNDED. REFER
TO OPERATING INSTRUCTIONS IN
CHAPTER 3.**

7. Connect H.V. Interconnect Cable from Master J1 to Slave 1 J2.

8. Connect H.V. Interconnect Cable from Slave 1 J1 to Slave 2 J2.

| Output Voltage | Interconnect Cable |
|----------------|--------------------|
| 1kV to 6kV | 302039-015 |
| 8kV to 40kV | 302039-010 |
| 50kV to 60kV | 302039-011 |
| 70kV to 120kV | 403839-001 |

9. Connect H.V. output cable to Slave 2 J1.

| Output Voltage | Interconnect Cable |
|----------------|--------------------|
| 1kV to 6kV | 100161-020 |
| 8kV to 40kV | 100161-012 |
| 50kV to 60kV | 100161-019 |
| 70kV to 120kV | 403625-002 |

NOTE: Before operating this system, refer to operating instructions in Chapter 3.

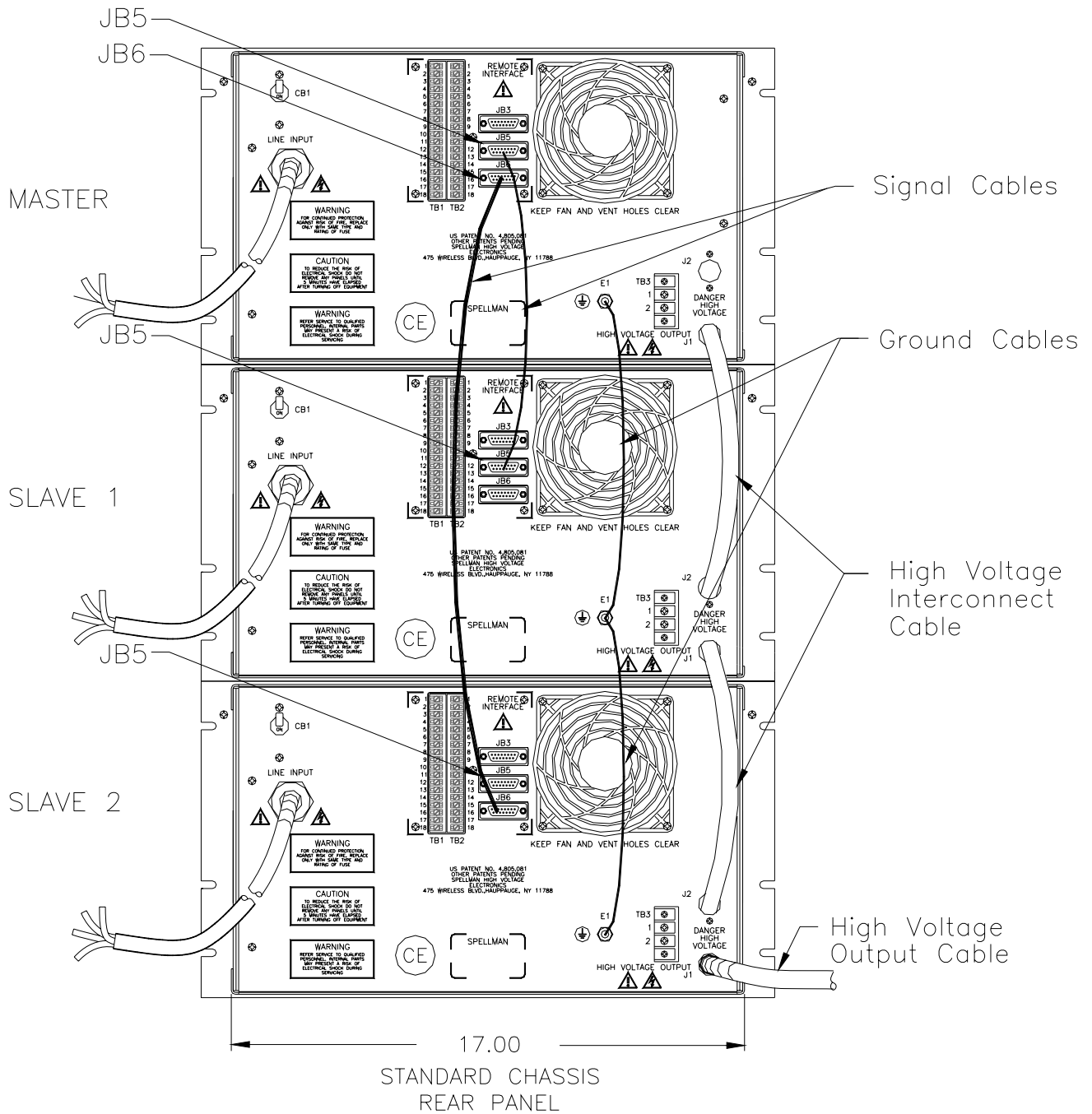

Figure 5.6 18kW Installation Drawing

5.14 Reversible Polarity Option PN

5.14.1 Models Requiring Multiplier Replacement

Follow standard high voltage safety practices before attempting to replace the multiplier assembly. De-energize the input line mains and discharge the high voltage output.

10-60kV Models: Refer to multiplier replacement procedure, SHV 403711-001 (located in Schematic section of manual).

70-120kV Models: Refer to multiplier replacement procedure, SHV 403943-001 (located in Schematic section of manual).

5.14.2 Rear Panel Polarity Reversible Models

Rear panel reversible systems utilize a high voltage switch located on the Inverter chassis rear panel as shown in Figure 5.7.

The polarity of Rear Panel Reversible models is changed by the following procedure:

Note: Follow paragraphs 1-6 for standard SR models. Paragraphs 7 and 8 are provided for PFE models with polarity indicator LED's.

1. De-energize the high voltage output.

WARNING

NEVER ATTEMPT TO CHANGE THE POWER SUPPLY POLARITY WITH THE HIGH VOLTAGE ENERGIZED. SERIOUS PERSONAL INJURY AND OR DAMAGE TO THE POWER SUPPLY CAN OCCUR IF THE POLARITY IS SWITCHED WHILE THE HIGH VOLTAGE IS ENERGIZED.

2. Loosen the (4) captive screws securing the high voltage switch to the SR rear panel. (See Figure 5.7)
3. Grasp the high voltage switch by the handle and pull straight out away from the rear panel.
4. Rotate the handle 90° and re-insert back into the receptacle.

The alignment of the switch handle with the silk-screen symbols provided on the rear panel indicates the selected polarity. (See Figure 5.7)
5. Tighten the (4) captive screws to secure the switch in place. (Failure to secure the switch properly will cause an Interlock Open fault to be displayed on the SR front panel.)
6. This completes the Polarity Reversal Procedure for standard SR models. Power supply polarity will be displayed on the front panel kV meter by the addition of a - symbol preceding the voltage display when in Negative mode. Operation is per chapter 3, Operating Instructions.
7. SRPFE models with polarity indicator LED's display the selected polarity on the Master chassis front panel, Slave chassis front panel or the Clamp chassis front panel by illuminating LEDs. Red LED's indicate positive mode, Green LED's indicate Negative mode.
8. Clamp chassis polarity is selected the same as the SR Inverter chassis. Repeat steps 2-6 for the Clamp Chassis.

8.1 Some systems that include a Clamp Chassis also have a polarity interlock. If any chassis is configured with its polarity opposite of the other installed chassis's, the high voltage cannot be energized. This is indicated on the SR Master chassis front panel by illuminating the INTERLOCK OPEN lamp. The two polarity LED's on the Clamp chassis front panel will be extinguished.

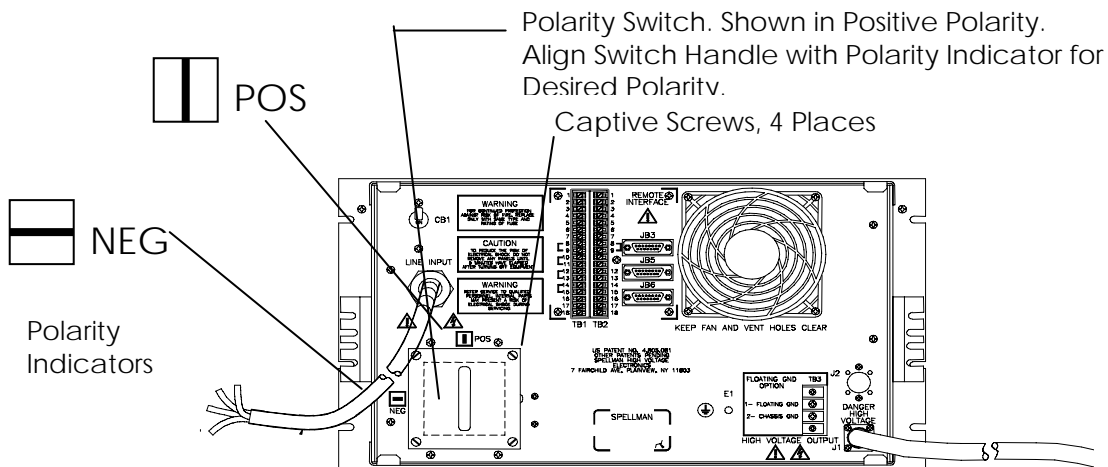

Figure 5.7 Rear Panel Polarity Reversal Switch

5.15 External Fault Relay Option EFR

The external fault relay option provides a set of customer accessible relay contacts that are controlled by the fault status circuitry of the applicable SR series power supply.

A standard SR series power supply will revert to the “power down” mode with a visual front panel indicator if any of the following fault conditions occur:

SYSTEM FAULT
OVER VOLTAGE
OVER CURRENT
OVER TEMPERATURE
REGULATION ERROR
ARC (Shutdown)
OVER POWER

With installation of the EFR option, if any of these faults occur, a relay will be activated to provide a remote indication that the power supply has reverted to the POWER DOWN mode. Common, normally open, and normally closed set of contacts are provided.

Relay contact ratings are UL/CSA recognized at 1A @ 30VDC, 0.5A @ 125VDC, or 0.3A @ 110VAC. Connections can be made as follows:

TB2-18 Relay Common
TB2-16 Normally Open
TB2-17 Normally Closed

Resetting the front panel fault and EFR relay is accomplished by toggling the control power on pushbutton switch, which reverts the power supply back to the “standby” mode.

5.16 External Arc Limiter And KV Feedback Chassis

Models that use an external Arc Limiting Resistor are provided with a separate KV feedback chassis to allow the power supply to regulate voltage from the load side of the external limiter. Refer to Figure 5.8 for cabling and installation instructions.

5.17 Arc Sensitivity Selector Switch

Some models that use an external Arc Limiting Resistor have the capability to change the arc sensitivity. A two-position switch is installed on the System Control PWB. The switch allows the operator to select the desired sensitivity for two different value external resistors.

Opening the front panel to the service position as described in paragraph 4.6 accesses the switch. The switch is located in the lower left hand corner of the System Control PWB, above connector JB6.

The sensitivity is selected by matching the switch position to the label provided on the inside surface of the front panel.

WARNING:

NEVER OPERATE THE SYSTEM WITH THE W1 OR W8 DISCONNECTED. W1 AND W8 ARE REQUIRED FOR VOLTAGE REGULATION. FAILURE TO CONNECT THESE CABLES WILL CAUSE THE OUTPUT VOLTAGE TO BE UN-REGULATED AND DAMAGE TO THE POWER SUPPLY AND EXTERNALLY CONNECTED EQUIPMENT MAY OCCUR.

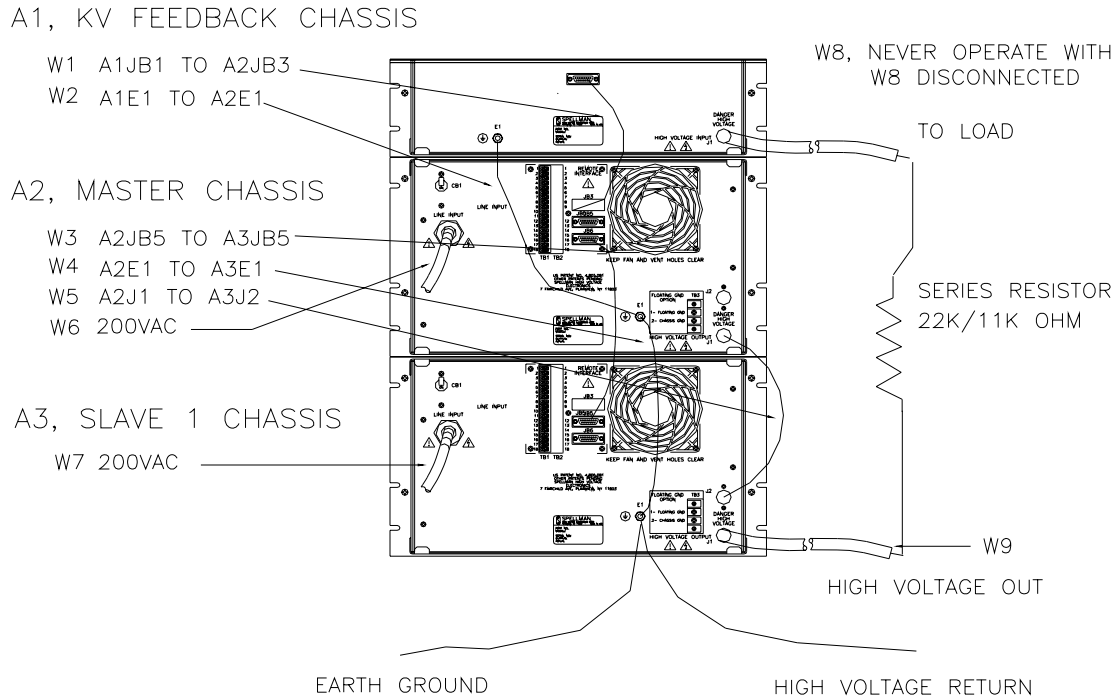

SYSTEM CABLE INSTALLATION

| CABLE | FROM | TO | DESCRIPTION |
|-------|--------|--------------|------------------------|
| W1 | A1-JB1 | A2-JB3 | KV FEEDBACK CABLE |
| W2 | A1-E1 | A2-E1 | GND CABLE, 302085-009 |
| W3 | A2-JB5 | A3-JB5 | SIG. CABLE, 302979-001 |
| W4 | A2-E1 | A3-E1 | GND CABLE, 302085-009 |
| W5 | A2-J1 | A3-J2 | HV JUMPER, 403839-001 |
| W8 | A1-J1 | R LIMIT/LOAD | HV CABLE, 403625-003 |
| W9 | A2-J1 | R LIMIT | HV CABLE, 403625-003 |

12 KW INSTALLATION WITH KVFDK CHASSIS

FIGURE 5.8

Chapter 6

MAINTENANCE

This section describes periodic servicing and performance testing procedures.

WARNING

THIS POWER SUPPLY GENERATES VOLTAGES THAT ARE DANGEROUS AND MAY BE FATAL.

OBSERVE EXTREME CAUTION WHEN WORKING WITH HIGH VOLTAGE.

6.1 Periodic Servicing

Approximately once a year (more often in high dust environments), disconnect the power to the unit and remove the top cover. Use compressed air to blow dust out of the inside of the unit. Avoid touching or handling the high voltage assembly. Be sure that the fan is not obstructed and spins freely. The fan has sealed bearings and does not need lubrication. Be sure to replace the top cover before operating for proper cooling.

Turn the chassis over and remove the bottom cover. Locate the mounting brackets holding the high voltage enclosure cover. Remove these brackets and the enclosure cover. Use compressed air to blow dust out. NOTE: On 6kV and below, no high voltage enclosure is used. Avoid touching or handling the high voltage assembly. Be sure to replace the enclosure and the bottom cover before operating the unit.

6.2 Performance Test

WARNING

HIGH VOLTAGE IS DANGEROUS.

ONLY QUALIFIED PERSONNEL SHOULD PERFORM THESE TESTS.

High voltage test procedures are described in Bulletin STP-783, Standard Test Procedures for High Voltage Power Supplies. Copies can be obtained from the Spellman Customer Service Department. Test equipment, including an oscilloscope, a high impedance voltmeter, and a high voltage divider such as the Spellman HVD-100 or HVD-200, is needed for performance tests. All test components must be rated for operating voltage.

6.3 High Voltage Dividers

High voltage dividers for precise measurements of output voltage with an accuracy up to 0.1% are available from Spellman. The HVD-100 is used for voltages up to 100kV. The HVD-200 measures up to 200kV. The Spellman divider is designed for use with differential voltmeters or high impedance digital voltmeters. The high input impedance is ideal for measuring high voltage low current sources, which would be overloaded by traditional lower impedance dividers.

Chapter 7

REPLACEMENT PARTS

7.1 Replacement Parts

Contact the Spellman Customer Service Department for parts lists for specific models.

Spellman provides parts and subassemblies for its high voltage power supplies but recommends that only qualified personnel perform the repair. High voltage is dangerous; even minor mistakes in repairs can have serious consequences.

When requesting parts please give the model number and serial number of the power supply.

7.2 Correspondence And Ordering Spare Parts

Each Spellman power supply has an identification label on the rear of the chassis that bears its model and serial number.

When requesting engineering or applications information, please state the model and serial number of the power supply. If specific components or circuit sections are involved in the inquiry, it is helpful to indicate the component symbol number(s) shown on the applicable schematic diagram.

When ordering spare parts, please specify the part's description, the part's reference designation or part number, and the model and serial number of the unit.

Chapter 8

FACTORY SERVICE

8.1 Warranty Repairs

During the Warranty period, Spellman will repair all units free of charge. The Warranty is void if the unit is worked on by other than Spellman personnel. See the Warranty in the rear of this manual for more information. Follow the return procedures described in Section 8.2. The customer shall pay for shipping to and from Spellman.

8.2 Factory Service Procedures

Spellman has a well-equipped factory repair department. If a unit is returned to the factory for calibration or repair, a detailed description of the specific problem should be attached.

For all units returned for repair, please obtain an authorization to ship from the Customer Service Department, either by phone or mail prior to shipping. When you call, please state the model and serial numbers, which are on the plate on the rear of the power supply, and the purchase order number for the repair. A Return Material Authorization Code Number (RMA Number) is needed for all returns. This RMA Number should be marked clearly on the outside of the shipping container. Packages received without an RMA Number will be returned to the customer. The Customer shall pay for shipping to and from Spellman.

A preliminary estimate for repairs will be given by phone by Customer Service. A purchase order for this amount is requested upon issuance of the RMA Number. A more detailed estimate will be made when the power supply is received at the Spellman Repair Center. In the event that repair work is extensive, Spellman will call to seek additional authorization from your company before completing the repairs.

8.3 Ordering Options and Modifications

Many of the options listed in Chapter 5 can be retrofitted into Spellman power supplies by our factory. For prices and arrangements, contact our Sales Department.

8.4 Shipping Instructions

All power supplies returned to Spellman must be sent shipping prepaid. Pack the units carefully and securely in a suitable container, preferably in the original container, if available. The power supply should be surrounded by at least four inches of shock absorbing material. Please return all associated materials, i.e. high voltage output cables, interconnection cables, etc., so that we can examine and test the entire system.

All correspondence and phone calls should be directed to:

Spellman High Voltage Electronics Corp.
475 Wireless Boulevard
Hauppauge, New York 11788
TEL: (631) 630-3000 FAX: (631) 435-1620
E-Mail: sales@Spellmanhv.com
<http://www.spellmanhv.com>

SPELLMAN HIGH VOLTAGE ELECTRONICS

WARRANTY

Spellman High Voltage Electronics ("**Spellman**") warrants that all power supplies it manufactures will be free from defects in materials and factory workmanship, and agrees to repair or replace, without charge, any power supply that under normal use, operating conditions and maintenance reveals during the warranty period a defect in materials or factory workmanship. The warranty period is twelve (12) months from the date of shipment of the power supply. With respect to standard SL power supplies (not customized) the warranty period is thirty-six (36) months from the date of shipment of the power supply.

This warranty does not apply to any power supply that has been:

- Disassembled, altered, tampered, repaired or worked on by persons unauthorized by **Spellman**;
- subjected to misuse, negligent handling, or accident not caused by the power supply;
- installed, connected, adjusted, or used other than in accordance with the original intended application and/or instructions furnished by **Spellman**.

THE FOREGOING WARRANTY IS IN LIEU OF ALL OTHER WARRANTIES, EXPRESS OR IMPLIED, INCLUDING THOSE OF MERCHANTABILITY OR FITNESS FOR A PARTICULAR PURPOSE.

The buyer's sole remedy for a claimed breach of this warranty, and **Spellman's** sole liability is limited, at **Spellman's** discretion, to a refund of the purchase price or the repair or replacement of the power supply at **Spellman's** cost. The buyer will be responsible for shipping charges to and from **Spellman's** plant. The buyer will not be entitled to make claim for, or recover, any anticipatory profits, or incidental, special or consequential damages resulting from, or in any way relating to, an alleged breach of this warranty.

No modification, amendment, supplement, addition, or other variation of this warranty will be binding unless it is set forth in a written instrument signed by an authorized officer of **Spellman**.

Factory Service Procedures

For an authorization to ship contact **Spellman's** Customer Service Department. Please state the model and serial numbers, which are on the plate on the rear panel of the power supply and the reason for return. A Return Material Authorization Code Number (RMA number) is needed from **Spellman** for all returns. The RMA number should be marked clearly on the outside of the shipping container. Packages received without an RMA Number may delay return of the product. The buyer shall pay shipping costs to and from **Spellman**. Customer Service will provide the Standard Cost for out-of-warranty repairs. A purchase order for this amount is requested upon issuance of the RMA Number (in-warranty returns must also be accompanied by a "zero-value" purchase order). A more detailed estimate may be made when the power supply is received at **Spellman**. In the event that the cost of the actual repair exceeds the estimate, **Spellman** will contact the customer to authorize the repair.

Factory Service Warranty

Spellman will warrant for three (3) months or balance of product warranty, whichever is longer, the repaired assembly/part/unit. If the same problem shall occur within this warranty period **Spellman** shall undertake all the work to rectify the problem with no charge and/or cost to the buyer. Should the cause of the problem be proven to have a source different from the one that has caused the previous problem and/or negligence of the buyer, **Spellman** will be entitled to be paid for the repair.

Spellman Worldwide Service Centers

For a complete listing of **Spellman's** Global Service facilities please go to:
<http://www.spellmanhv.com/customerservice/service.asp>

THIS INFORMATION CONTAINED HEREIN IS PROPRIETARY TO SPELLMAN HIGH VOLTAGE ELECTRONICS CORP. AND IS TO BE USED ONLY FOR THE PURPOSES INTENDED AND IS NOT TO BE REPRODUCED EITHER IN WHOLE OR PART WITHOUT THE EXPRESS WRITTEN PERMISSION OF SPELLMAN HIGH VOLTAGE ELECTRONICS CORP.

| REVISIONS | | APPROVED | | | | |
|-----------|-----------------------|----------|-------------|----------|---------|---------|
| LTR | DESCRIPTION | DATE | MECH DESIGN | PROJ ENG | QUALITY | MFG ENG |
| A | RELEASED PER EDR 2566 | 3/23/90 | N/A | N/A | N/A | N/A |
| B | REVISED PER ECN 5443 | 2/7/91 | J.A. | B.S. | X.X. | N/A |
| C | REVISED PER ECN 6200 | 9/18/92 | J.A. | B.S. | X.X. | N/A |
| D | REVISED PER ECN 7790 | 2/24/94 | J.A. | B.S. | X.X. | N/A |

P/O PWB ASSY 403446-001
FRONT PANEL INTERFACE PWB

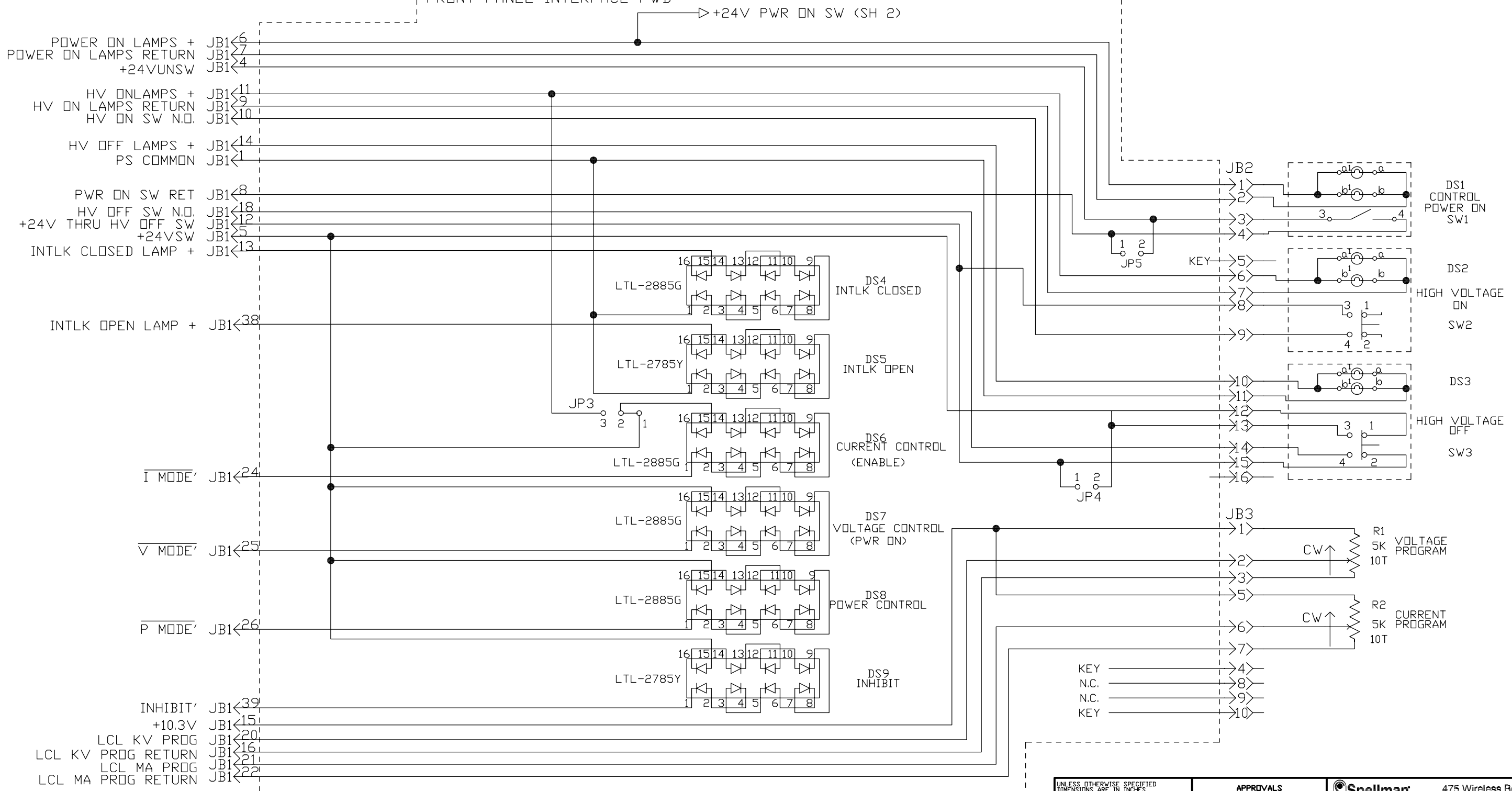

| | | | | | | | | |
|---|----------------|------------|----------------------|------|---------|--|----------------|-------------|
| UNLESS OTHERWISE SPECIFIED DIMENSIONS ARE IN INCHES TOLERANCES ARE: | | | APPROVALS | | | 475 Wireless Boulevard Hauppauge, New York 11788 | | |
| FRACTIONS ± | DECIMALS .XX ± | ANGLES ° ± | DRAWN | BY | DATE | SCHEMATIC DIAGRAM FRONT PANEL SR6 | | |
| | | | CHECKED | J.A. | 2/15/90 | | | |
| MATERIAL | | | MECH. DESIGN | J.A. | 3/22/90 | | | |
| | | | PROJ. ENG. | B.S. | 3/22/90 | | | |
| | | | Q.A. | X.X. | 3/22/90 | | | |
| FINISH | | | MFG. ENG. | N/A | N/A | SIZE | CODE IDENT NO. | DRAWING NO. |
| | | | | | | D | 10610 | 440372-001 |
| PART NO. | | | NEXT ASSY | | | USED ON | | |
| APPLICATION | | | DO NOT SCALE DRAWING | | | BREAK ALL SHARP EDGES & CORNERS | | |
| 440372-003 | | | 403446-003 | | | SR6 | | |
| 440372-002 | | | 403446-002 | | | SR6 | | |
| 440372-001 | | | 403446-001 | | | SR6 | | |
| SCALE: NONE | | | FILE# | | | SHEET 1 OF 2 | | |

| PART NO. | NEXT ASSY | USED ON |
|------------|------------|---------|
| 440372-003 | 403446-003 | SR6 |
| 440372-002 | 403446-002 | SR6 |
| 440372-001 | 403446-001 | SR6 |

THIS INFORMATION CONTAINED HEREIN IS PROPRIETARY TO SPELLMAN HIGH VOLTAGE ELECTRONICS CORP. AND IS TO BE USED ONLY FOR THE PURPOSES INTENDED AND IS NOT TO BE REPRODUCED EITHER IN WHOLE OR PART WITHOUT THE EXPRESS WRITTEN PERMISSION OF SPELLMAN HIGH VOLTAGE ELECTRONICS CORP.

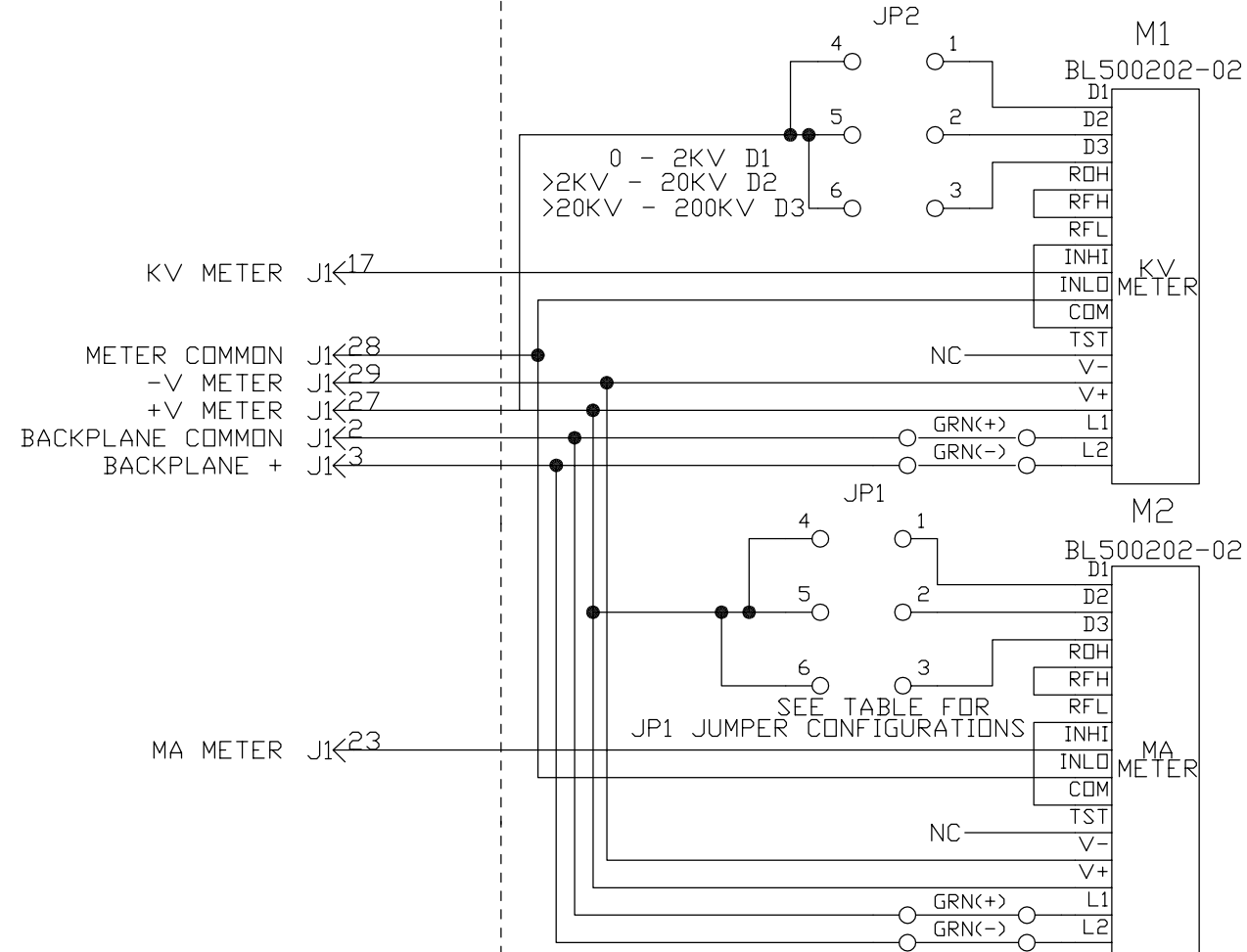
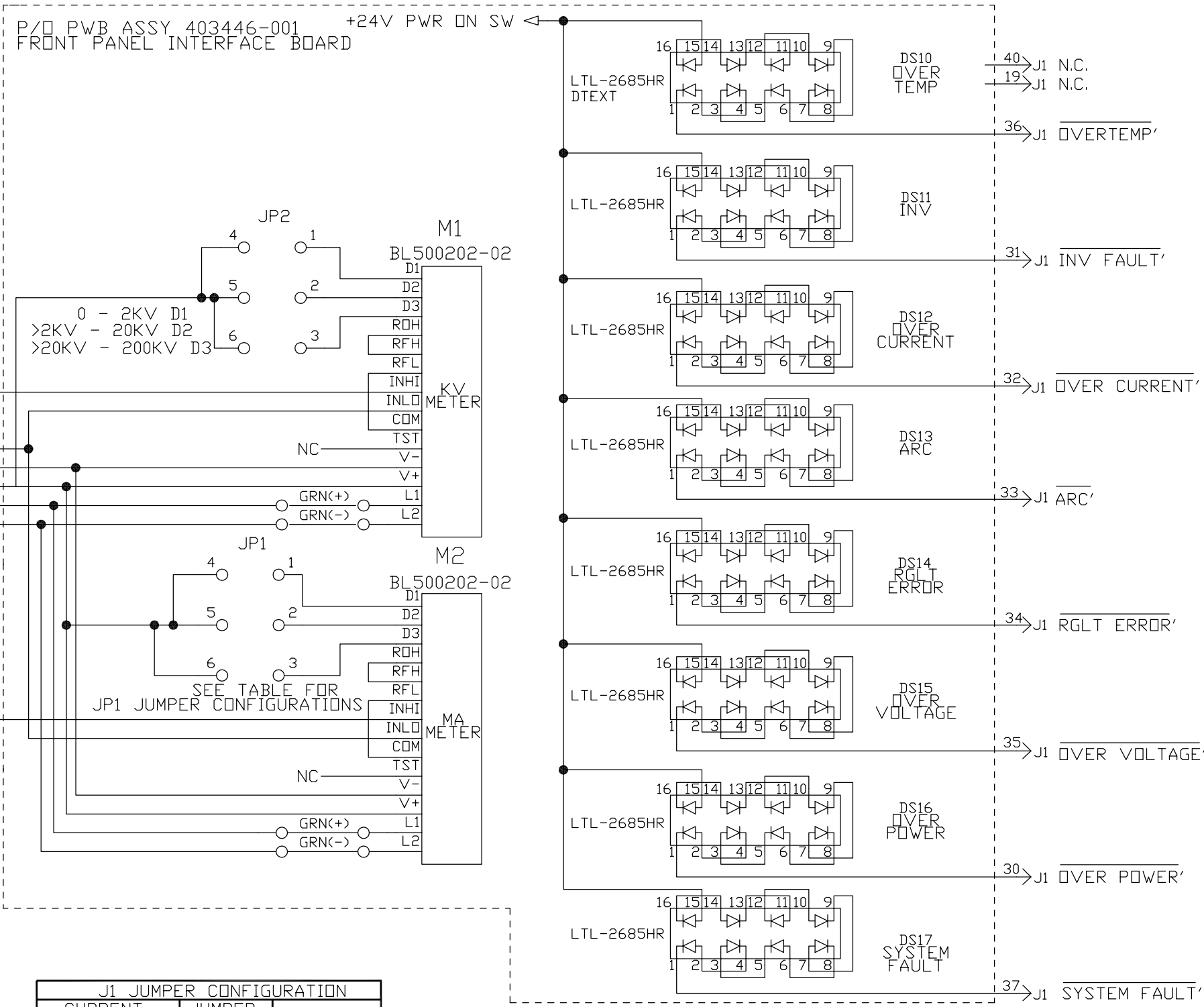

| J1 JUMPER CONFIGURATION | | |
|-------------------------|-----------------|-------------|
| CURRENT (I) | JUMPER LOCATION | RANGE |
| I > 2A | D2 | 02.00-06.00 |
| 1A < I < 2A | D1 | 1.000-1.999 |
| 200mA < I < 1000mA | - | 0200-0999 |
| 20mA < I < 200mA | D3 | 020.0-199.9 |
| 2mA < I < 20mA | D2 | 02.00-19.99 |
| 0 < I < 2mA | D1 | 0.000-1.999 |

Spellman 475 Wireless Boulevard
Hauppauge, New York 11788

**SCHEMATIC DIAGRAM
FRONT PANEL
SR6**

| | | | |
|-------------|----------------|--------------|-----|
| SIZE | CODE IDENT NO. | DRAWING NO. | D |
| D | 10610 | 440372-001 | REV |
| SCALE: NONE | FILE# | SHEET 2 OF 2 | |

THIS INFORMATION CONTAINED HEREIN IS PROPRIETARY TO SPELLMAN HIGH VOLTAGE ELECTRONICS CORP. AND IS TO BE USED ONLY FOR THE PURPOSES INTENDED AND IS NOT TO BE REPRODUCED EITHER IN WHOLE OR PART WITHOUT THE EXPRESS WRITTEN PERMISSION OF SPELLMAN HIGH VOLTAGE ELECTRONICS CORP.

| REVISIONS | | | | APPROVED | | |
|-----------|----------------------|---------|-------------|----------|---------|---------|
| LTR | DESCRIPTION | DATE | MECH DESIGN | PROJ ENG | QUALITY | MFG ENG |
| A | RELEASE PER EDR 2566 | 3/23/90 | J.A. | B.S. | X.X. | N/A |
| B | REVISED PER ECN 5350 | 1/11/91 | N/A | B.S. | X.X. | N/A |

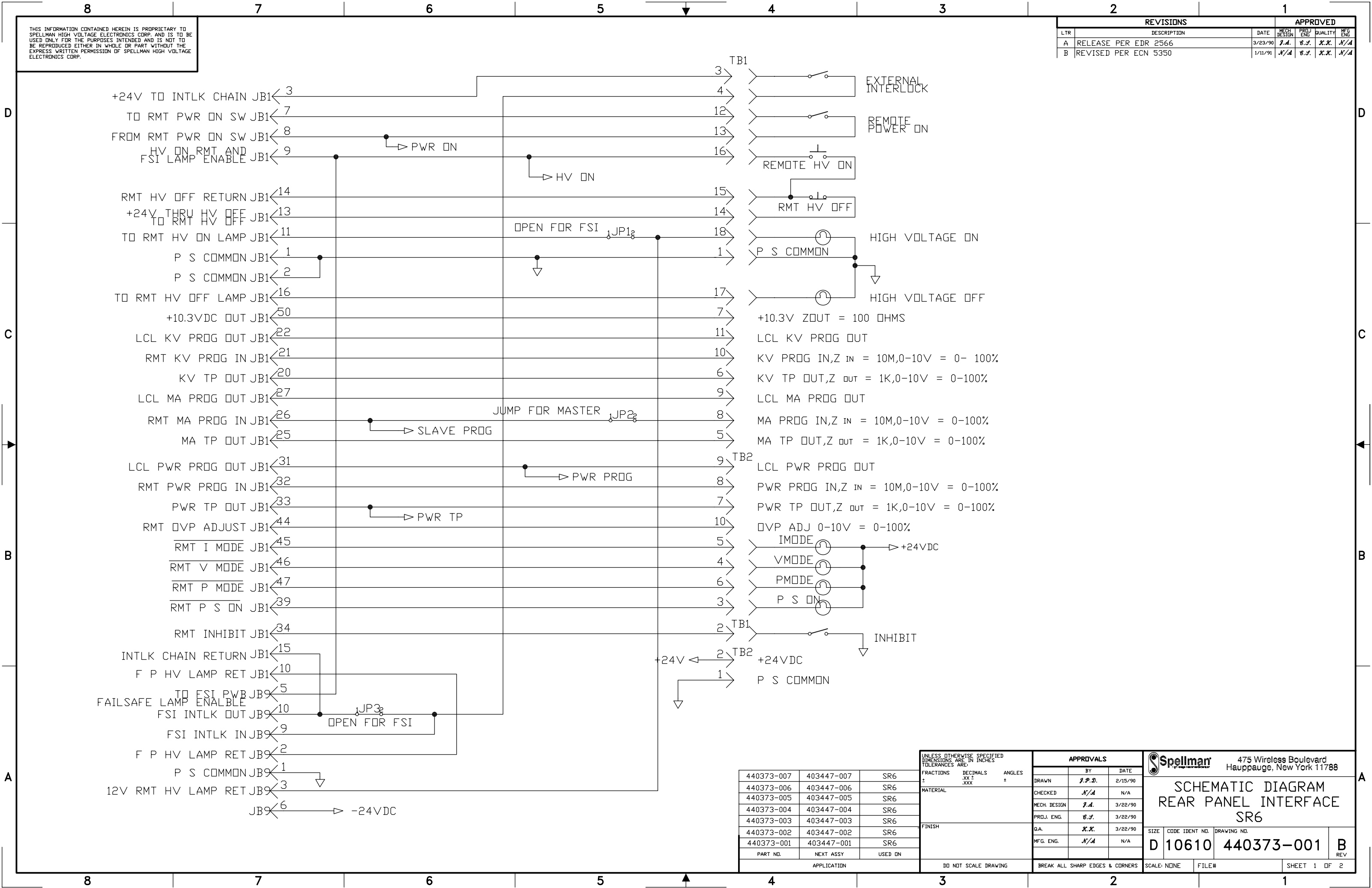

| PART NO. | NEXT ASSY | USED ON |
|------------|------------|---------|
| 440373-007 | 403447-007 | SR6 |
| 440373-006 | 403447-006 | SR6 |
| 440373-005 | 403447-005 | SR6 |
| 440373-004 | 403447-004 | SR6 |
| 440373-003 | 403447-003 | SR6 |
| 440373-002 | 403447-002 | SR6 |
| 440373-001 | 403447-001 | SR6 |

| UNLESS OTHERWISE SPECIFIED DIMENSIONS ARE IN INCHES TOLERANCES ARE: | | |
|---|----------|--------|
| FRACTIONS | DECIMALS | ANGLES |
| ± | .XX ± | ± |
| | .XXX | |

| APPROVALS | | |
|--------------|--------|---------|
| BY | DATE | |
| DRAWN | J.P.D. | 2/15/90 |
| CHECKED | N/A | N/A |
| MECH. DESIGN | J.A. | 3/22/90 |
| PROJ. ENG. | B.S. | 3/22/90 |
| Q.A. | X.X. | 3/22/90 |
| MFG. ENG. | N/A | N/A |

Spellman 475 Wireless Boulevard
Hauppauge, New York 11788

**SCHEMATIC DIAGRAM
REAR PANEL INTERFACE
SR6**

| | | | |
|------|----------------|-------------|-----|
| SIZE | CODE IDENT NO. | DRAWING NO. | REV |
| D | 10610 | 440373-001 | B |

SCALE: NONE FILE# SHEET 1 OF 2

DO NOT SCALE DRAWING BREAK ALL SHARP EDGES & CORNERS

THIS INFORMATION CONTAINED HEREIN IS PROPRIETARY TO SPELLMAN HIGH VOLTAGE ELECTRONICS CORP. AND IS TO BE USED ONLY FOR THE PURPOSES INTENDED AND IS NOT TO BE REPRODUCED EITHER IN WHOLE OR PART WITHOUT THE EXPRESS WRITTEN PERMISSION OF SPELLMAN HIGH VOLTAGE ELECTRONICS CORP.

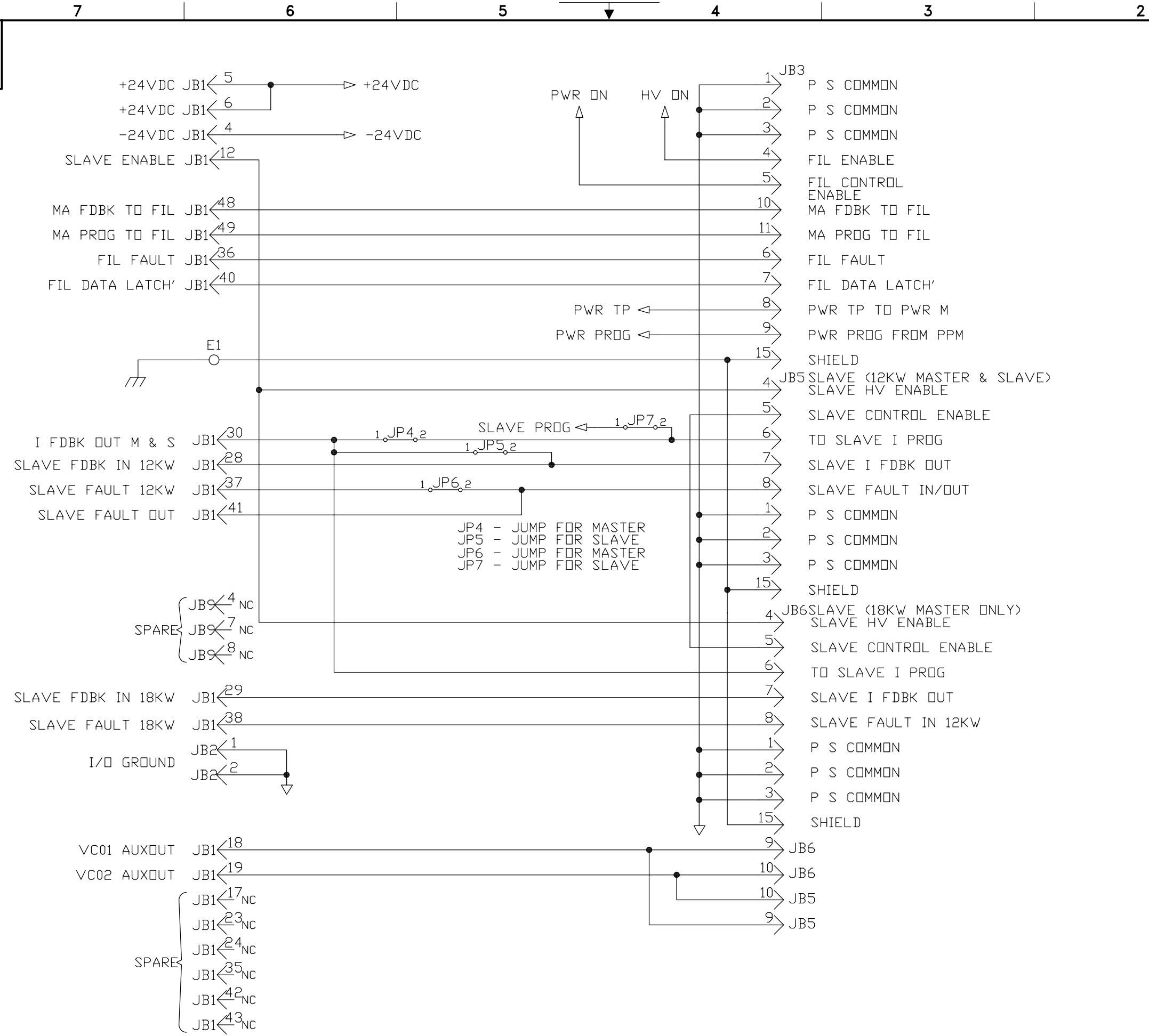

| | | | |
|---|----------------|---|-----|
| Spellman | | 475 Wireless Boulevard Hauppauge, New York 11788 | |
| SCHEMATIC DIAGRAM REAR PANEL INTERFACE SR6 | | | |
| SIZE | CODE IDENT NO. | DRAWING NO. | REV |
| D | 10610 | 440373-001 | B |
| SCALE: NONE | FILE# | SHEET 2 OF 2 | |

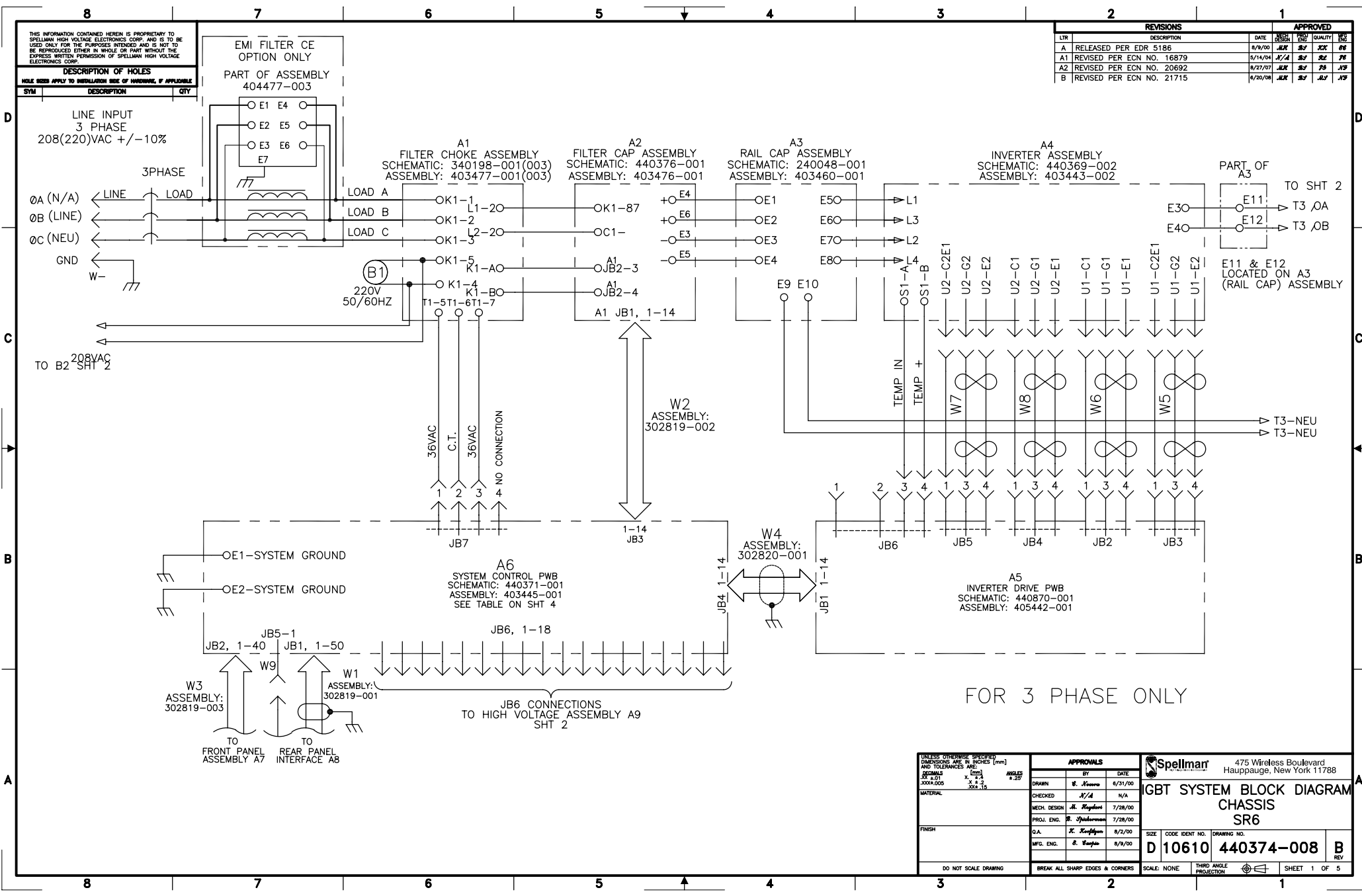

| REVISIONS | | | | APPROVED | |
|-----------|---------------------------|---------|--------|----------|-----|
| LTR | DESCRIPTION | DATE | DESIGN | CHK | APP |
| A | RELEASED PER EDR 5186 | 8/9/00 | JJK | JJK | JJK |
| A1 | REVISED PER ECN NO. 16879 | 8/14/04 | JJK | JJK | JJK |
| A2 | REVISED PER ECN NO. 20692 | 8/27/07 | JJK | JJK | JJK |
| B | REVISED PER ECN NO. 21715 | 8/29/08 | JJK | JJK | JJK |

THIS INFORMATION CONTAINED HEREIN IS PROPRIETARY TO SPELLMAN HIGH VOLTAGE ELECTRONICS CORP. AND IS TO BE USED ONLY FOR THE PURPOSES INTENDED AND IS NOT TO BE REPRODUCED EITHER IN WHOLE OR PART WITHOUT THE EXPRESS WRITTEN PERMISSION OF SPELLMAN HIGH VOLTAGE ELECTRONICS CORP.

DESCRIPTION OF HOLES
HOLE SIZES APPLY TO INSTALLATION SIDE OF HARDWARE, IF APPLICABLE

| SYM | DESCRIPTION | QTY |
|-----|-------------|-----|
| | | |

EMI FILTER CE OPTION ONLY
PART OF ASSEMBLY 404477-003

LINE INPUT
3 PHASE
208(220)VAC +/-10%

3PHASE

0A (N/A) ← LINE
0B (LINE)
0C (NEU)
GND
W-

TO B2 208VAC SHT 2

A1
FILTER CHOKE ASSEMBLY
SCHEMATIC: 340198-001(003)
ASSEMBLY: 403477-001(003)

A2
FILTER CAP ASSEMBLY
SCHEMATIC: 440376-001
ASSEMBLY: 403476-001

A3
RAIL CAP ASSEMBLY
SCHEMATIC: 240048-001
ASSEMBLY: 403460-001

A4
INVERTER ASSEMBLY
SCHEMATIC: 440369-002
ASSEMBLY: 403443-002

PART OF A3
TO SHT 2
E11 → T3-0A
E12 → T3-0B
E11 & E12 LOCATED ON A3 (RAIL CAP) ASSEMBLY

(B1)
220V
50/60HZ

W2 ASSEMBLY:
302819-002

W4 ASSEMBLY:
302820-001

OE1-SYSTEM GROUND
OE2-SYSTEM GROUND

A6
SYSTEM CONTROL PWB
SCHEMATIC: 440371-001
ASSEMBLY: 403445-001
SEE TABLE ON SHT 4

A5
INVERTER DRIVE PWB
SCHEMATIC: 440870-001
ASSEMBLY: 405442-001

JB2, 1-40
JB5-1
JB1, 1-50
W9
W1 ASSEMBLY:
302819-001
TO FRONT PANEL ASSEMBLY A7
TO REAR PANEL INTERFACE AB

JB6, 1-18
JB6 CONNECTIONS TO HIGH VOLTAGE ASSEMBLY A9 SHT 2

FOR 3 PHASE ONLY

| | | | |
|---|---|--|---|
| <small>UNLESS OTHERWISE SPECIFIED DIMENSIONS ARE IN INCHES [mm] AND TOLERANCES ARE:</small> DIMS: .010 [0.25] .004-.005 [0.10-0.13] .015 [0.38] .030 [0.76] .060 [1.52] .125 [3.18] .250 [6.35] .500 [12.70] 1.000 [25.40] 2.000 [50.80] 5.000 [127.00] 10.000 [254.00] | APPROVALS BY DATE DRAWN: B. Korman 6/31/00 CHECKED: JJK 4/A MECH. DESIGN: M. Korman 7/28/00 PROJ. ENG.: R. Spindlerman 7/28/00 Q.A.: K. Korman 8/2/00 MFG. ENG.: B. Korman 8/9/00 | | 475 Wireless Boulevard Hauppauge, New York 11788 IGBT SYSTEM BLOCK DIAGRAM CHASSIS SR6 SIZE: CODE IDENT NO. DRAWING NO. D 10610 440374-008 B REV |
| | DO NOT SCALE DRAWING | | |
| | BREAK ALL SHARP EDGES & CORNERS | | |
| | SCALE: NONE THIRD ANGLE PROJECTION | | |
| | SHEET 1 OF 5 | | |

THIS INFORMATION CONTAINED HEREIN IS PROPRIETARY TO SPELLMAN HIGH VOLTAGE ELECTRONICS CORP. AND IS TO BE USED ONLY FOR THE PURPOSES INTENDED AND IS NOT TO BE REPRODUCED EITHER IN WHOLE OR PART WITHOUT THE EXPRESS WRITTEN PERMISSION OF SPELLMAN HIGH VOLTAGE ELECTRONICS CORP.

HIGH VOLTAGE TRANSFORMER
COIL ASSEMBLY: 403517-TAB
SEE TABLE II

TO
RAIL CAP ASSEMBLY A3
SHT 1

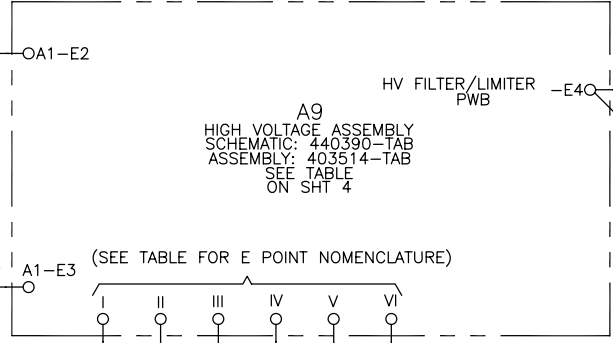
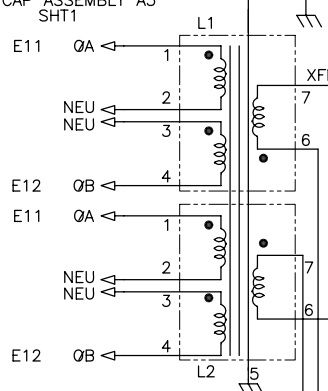

HV CONNECTOR ASSEMBLY
ASSEMBLY: 303006-TAB
SEE TABLE
ON SHT 4

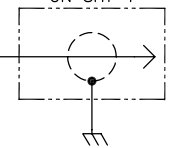

J1 HIGH VOLTAGE OUTPUT

E1 HIGH VOLTAGE RETURN

HV CONNECTOR ASSEMBLY
ASSEMBLY: 303006-TAB
SEE TABLE
ON SHT 4

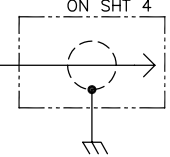

J2 HIGH VOLTAGE OUTPUT
(SLAVE UNITS ONLY)
SLAVE "DAISY CHAIN" CONNECTION

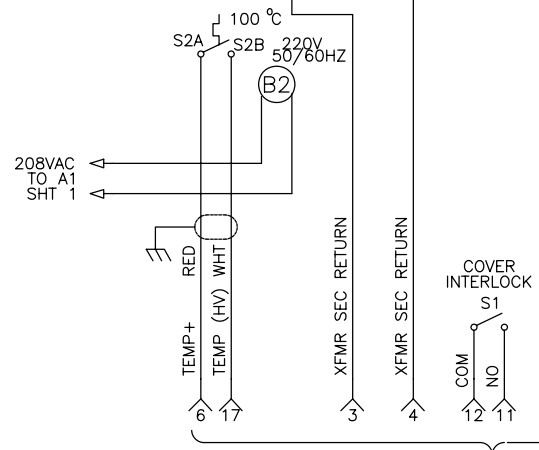

JB6 CONNECTIONS
TO SYSTEM CONTROL PWB A6
SHT 1

| APPLICATION | I | II | III | IV | V | VI |
|-------------|-------|-------|--------|--------|--------|-------|
| SR6 | A1-E1 | A1-E4 | - | A1-E9 | A1-E10 | - |
| X3583 | A1-E5 | A1-E8 | A1-E10 | A1-E12 | A9-E2 | - |
| X3875 | A1-E5 | A1-E8 | A1-E10 | A1-E12 | A9-E2 | - |
| X3896 | A1-E5 | A1-E8 | A1-E10 | A1-E12 | A9-E2 | A9-E1 |

X3896 ONLY

Spellman 475 Wireless Boulevard
Hauppauge, New York 11788

**IGBT SYSTEM BLOCK DIAGRAM
CHASSIS
SR6**

| | | | |
|------|----------------|-------------|-----|
| SIZE | CODE IDENT NO. | DRAWING NO. | REV |
| D | 10610 | 440374-008 | B |

SCALE: NONE THIRD ANGLE PROJECTION SHEET 2 OF 5

THIS INFORMATION CONTAINED HEREIN IS PROPRIETARY TO SPELLMAN HIGH VOLTAGE ELECTRONICS CORP. AND IS TO BE USED ONLY FOR THE PURPOSES INTENDED AND IS NOT TO BE REPRODUCED EITHER IN WHOLE OR PART WITHOUT THE EXPRESS WRITTEN PERMISSION OF SPELLMAN HIGH VOLTAGE ELECTRONICS CORP.

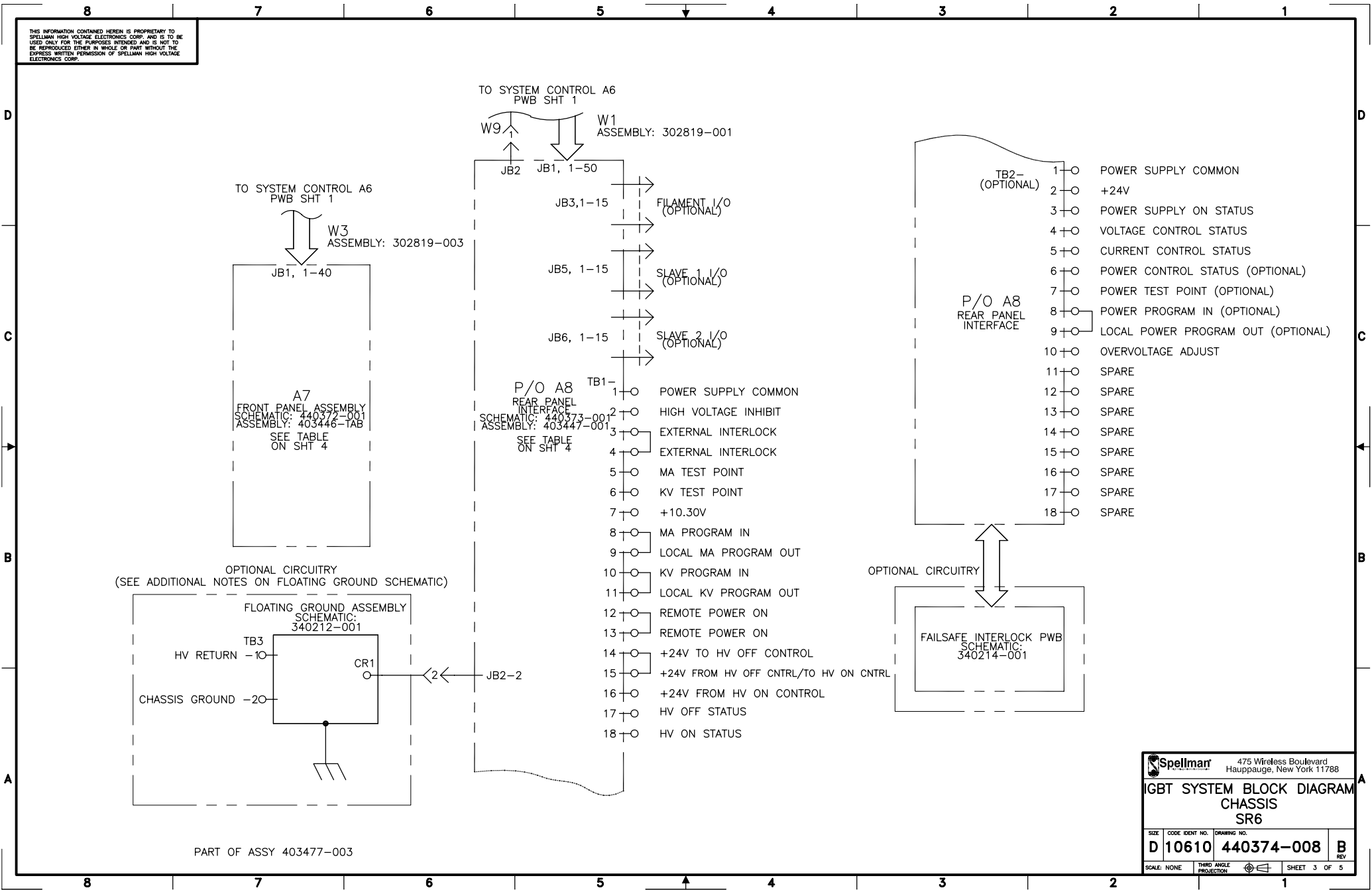

PART OF ASSY 403477-003

| | | | |
|--|---------------------------|---|----------|
| Spellman | | 475 Wireless Boulevard Hauppauge, New York 11788 | |
| IGBT SYSTEM BLOCK DIAGRAM CHASSIS SR6 | | | |
| SIZE | CODE IDENT NO. | DRAWING NO. | B REV |
| D | 10610 | 440374-008 | |
| SCALE: NONE | THIRD ANGLE PROJECTION | SHEET 3 OF 5 | |

THIS INFORMATION CONTAINED HEREIN IS PROPRIETARY TO SPELLMAN HIGH VOLTAGE ELECTRONICS CORP. AND IS TO BE USED ONLY FOR THE PURPOSES INTENDED AND IS NOT TO BE REPRODUCED EITHER IN WHOLE OR PART WITHOUT THE EXPRESS WRITTEN PERMISSION OF SPELLMAN HIGH VOLTAGE ELECTRONICS CORP.

| KV MA | DESCRIPTION | A6 SYS CONT BD 403445-001 | A7 | | A8 REAR PANEL INTERFACE BD 403447-001 | A9 MULTIPLIER ASSY 403514-TAB | L1,L2 HV XFMR WINDING 403517-TAB | J1,J2 HV CONNECTOR |
|------------|-------------|---------------------------------|---|--|--|--|---|--------------------------|
| | | | FRONT PANEL INTERFACE BD 403446-TAB | DECIMAL POINT JUMPERS JP1,JP2 NOT REQD FOR SLAVE | | | | |
| 10 600 | STANDARD | K59,K73,K95 | | | K88 | | | |
| | MASTER 12KW | | 403446-001,JP3(1,2) | JP1 (N/A) | K89 | 403514-001/101 | 403517-004 | 303006-001 |
| | MASTER 18KW | K59,K73,K96 | | | K90 | | | |
| SLAVE | | 403446-002,JP3(2,3) | JP2 (2,5) | K91 | | | | |
| 15 400 | STANDARD | K60,K74,K95 | | | K88 | | | |
| | MASTER 12KW | | 403446-001,JP3(1,2) | JP1 (N/A) | K89 | 403514-015/115 | 403517-005 | 303006-001 |
| | MASTER 18KW | K60,K74,K96 | | | K90 | | | |
| SLAVE | | 403446-002,JP3(2,3) | JP2 (2,5) | K91 | | | | |
| 20 300 | STANDARD | K61,K75,K95 | | | K88 | | | |
| | MASTER 12KW | | 403446-001,JP3(1,2) | JP1 (N/A) | K89 | 403514-002/102 | 403517-002 | 303006-001 |
| | MASTER 18KW | K61,K75,K96 | | | K90 | | | |
| SLAVE | | 403446-002,JP3(2,3) | JP2 (2,5) | K91 | | | | |
| 30 200 | STANDARD | K62,K76,K95 | | | K88 | | | |
| | MASTER 12KW | | 403446-001,JP3(1,2) | JP1 (N/A) | K89 | 403514-003/103 | 403517-002 | 303006-001 |
| | MASTER 18KW | K62,K76,K96 | | | K90 | | | |
| SLAVE | | 403446-002,JP3(2,3) | JP2 (3,6) | K91 | | | | |
| 40 150 | STANDARD | K63,K77,K95 | | | K88 | | | |
| | MASTER 12KW | | 403446-001,JP3(1,2) | JP1 (3,6) | K89 | 403514-004/104 | 403517-005 | 303006-001 |
| | MASTER 18KW | K63,K77,K96 | | | K90 | | | |
| SLAVE | | 403446-002,JP3(2,3) | JP2 (3,6) | K91 | | | | |
| 50 120 | STANDARD | K64,K78,K95 | | | K88 | | | |
| | MASTER 12KW | | 403446-001,JP3(1,2) | JP1 (3,6) | K89 | 403514-005/105 | 403517-003 | 303006-002 |
| | MASTER 18KW | K64,K78,K96 | | | K90 | | | |
| SLAVE | | 403446-002,JP3(2,3) | JP2 (3,6) | K91 | | | | |
| 60 100 | STANDARD | K65,K79,K95 | | | K88 | | | |
| | MASTER 12KW | | 403446-001,JP3(1,2) | JP1 (3,6) | K89 | 403514-006/106 | 403517-003 | 303006-002 |
| | MASTER 18KW | K65,K79,K96 | | | K90 | | | |
| SLAVE | | 403446-002,JP3(2,3) | JP2 (3,6) | K91 | | | | |
| 70 85.7 | STANDARD | K66,K80,K95 | | | K88 | | | |
| | MASTER 12KW | | 403446-001,JP3(1,2) | JP1 (3,6) | K89 | 403609-007/107 | 403517-007 | 403777-001 |
| | MASTER 18KW | K66,K80,K96 | | | K90 | | | |
| SLAVE | | 403446-002,JP3(2,3) | JP2 (3,6) | K91 | | | | |
| 80 75 | STANDARD | K67,K81,K95 | | | K88 | | | |
| | MASTER 12KW | | 403446-001,JP3(1,2) | JP1 (3,6) | K89 | 403609-008/108 | 403517-007 | 403777-001 |
| | MASTER 18KW | K67,K81,K96 | | | K90 | | | |
| SLAVE | | 403446-002,JP3(2,3) | JP2 (3,6) | K91 | | | | |
| 8 750 | STANDARD | K139,K140,K95 | | | K88 | | | |
| | MASTER 12KW | | 403446-001,JP3(1,2) | JP1(N/A) | K89 | 403514-018/ 118 | 403517-003 | 303006-001 |
| | MASTER 18KW | K139,K140,K96 | | | K90 | | | |
| SLAVE | | 403446-002,JP3(2,3) | JP2(2,5) | K91 | | | | |

| KV MA | DESCRIPTION | A6 SYS CONT BD 403445-001 | A7 | | A8 REAR PANEL INTERFACE BD 403447-001 | A9 MULTIPLIER ASSY 403609-TAB | L1,L2 HV XFMR WINDING 403517-TAB | A10 J1,J2 HV CONNECTOR | |
|-------------|-------------|---------------------------------|---|--|--|--|---|---------------------------------|------|
| | | | FRONT PANEL INTERFACE BD 403446-TAB | DECIMAL POINT JUMPERS JP1,JP2 NOT REQD FOR SLAVE | | | | 403777-xxx MASTER/SLAVE | |
| 100 60 | STANDARD | K123,K125,K95 | | | K88 | | | | |
| | MASTER 12KW | | 403446-001,JP3(1,2) | JP1 (3,6) | K89 | 403609-010/110 | 403517-006 | -002 | -005 |
| | MASTER 18KW | K123,K125,K96 | | | K90 | | | | |
| SLAVE | | 403446-002,JP3(2,3) | JP2 (3,6) | K91 | | | | | |
| 110 54.5 | STANDARD | K360,K361,K95 | | | K88 | | | | |
| | MASTER 12KW | | 403446-001,JP3(1,2) | JP1 (N/A) | K89 | 403609-012/112 | 403517-007 | -003 | -006 |
| | MASTER 18KW | K360,K361,K96 | | | K90 | | | | |
| SLAVE | | 403446-002,JP3(2,3) | JP2 (3,6) | K91 | | | | | |
| 120 50 | STANDARD | K124,K126,K95 | | | K88 | | | | |
| | MASTER 12KW | | 403446-001,JP3(1,2) | JP1(N/A) | K89 | 403609-012/112 | 403517-006 | -003 | -006 |
| | MASTER 18KW | K124,K126,K96 | | | K90 | | | | |
| SLAVE | | 403446-002,JP3(2,3) | JP2(3,6) | K91 | | | | | |

OBSOLETE

Spellman 475 Wireless Boulevard
Hauppauge, New York 11788

**IGBT SYSTEM BLOCK DIAGRAM
CHASSIS
SR6**

| | | | |
|-------------|---------------------------|-------------|--------------|
| SIZE | CODE IDENT NO. | DRAWING NO. | B REV |
| D | 10610 | 440374-008 | |
| SCALE: NONE | THIRD ANGLE PROJECTION | | SHEET 4 OF 5 |

THIS INFORMATION CONTAINED HEREIN IS PROPRIETARY TO SPELLMAN HIGH VOLTAGE ELECTRONICS CORP. AND IS TO BE USED ONLY FOR THE PURPOSES INTENDED AND IS NOT TO BE REPRODUCED EITHER IN WHOLE OR PART WITHOUT THE EXPRESS WRITTEN PERMISSION OF SPELLMAN HIGH VOLTAGE ELECTRONICS CORP.

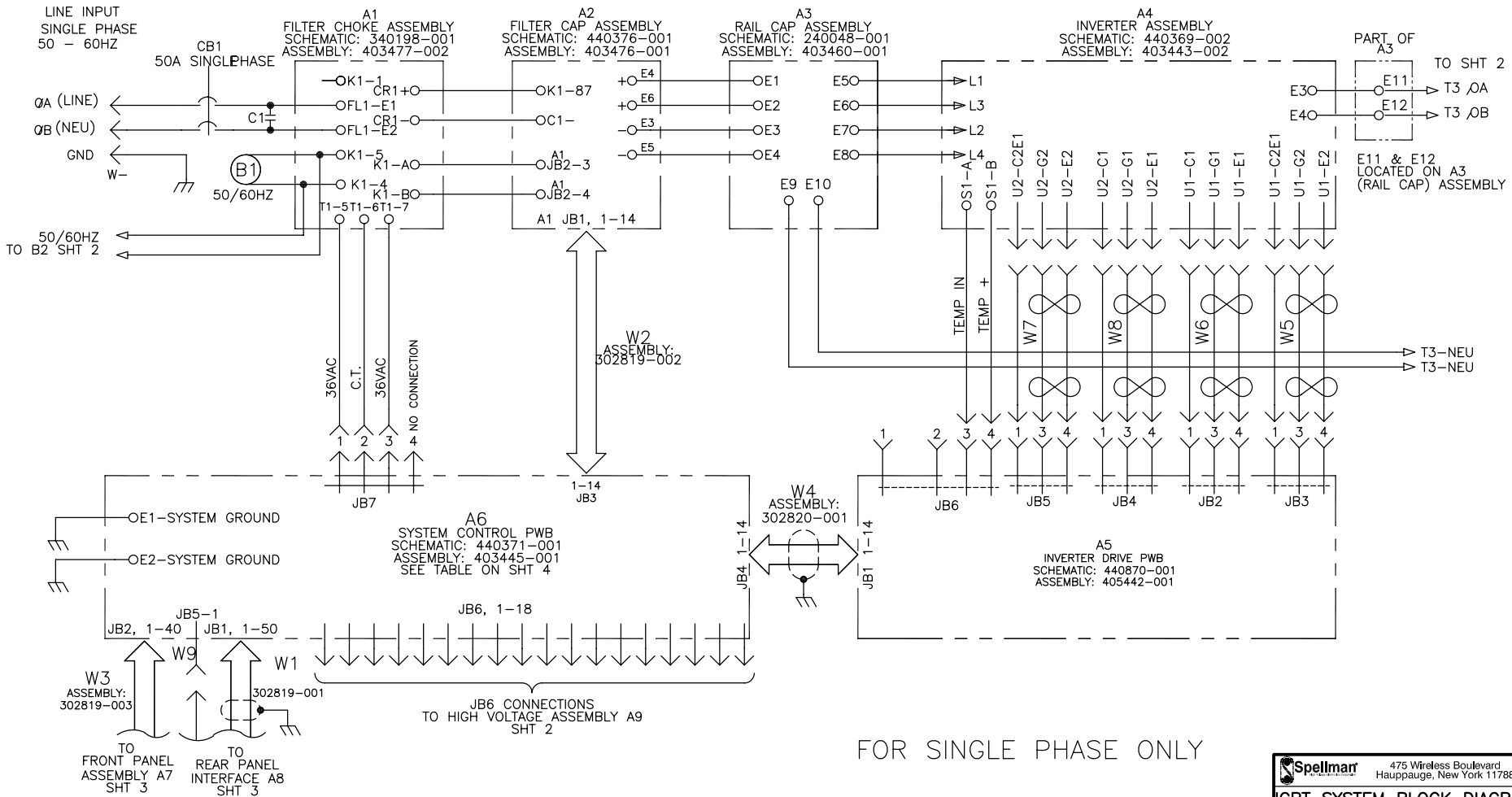

| | | | |
|--|------------------------|---|-----|
| | | 475 Wireless Boulevard Hauppauge, New York 11788 | |
| IGBT SYSTEM BLOCK DIAGRAM CHASSIS SR6 | | | |
| SIZE | CODE IDENT NO. | DRAWING NO. | REV |
| D | 10610 | 440374-008 | B |
| SCALE: NONE | THIRD ANGLE PROJECTION | SHEET 5 OF 5 | |

THIS INFORMATION CONTAINED HEREIN IS PROPRIETARY TO SPELLMAN HIGH VOLTAGE ELECTRONICS CORP. AND IS TO BE USED ONLY FOR THE PURPOSES INTENDED AND IS NOT TO BE REPRODUCED EITHER IN WHOLE OR PART WITHOUT THE EXPRESS WRITTEN PERMISSION OF SPELLMAN HIGH VOLTAGE ELECTRONICS CORP.

| REVISIONS | | APPROVED | | | |
|-----------|---------------------------------|----------|----------|---------|--------|
| LTR | DESCRIPTION | DATE | DESIGNED | QUALITY | DATE |
| A | PRELIMINARY RELEASE | 3/23/98 | | | |
| B | REVISED & RELEASED PER EDR 2758 | 2/7/99 | JA | CS | KK N/A |
| C | REVISED PER ECN 5418 | 3/15/99 | AP | CS | KK N/A |
| D | REVISED PER ECN 5700 | 4/18/99 | N/A | CS | KK N/A |
| E | REVISED PER ECN 5771 | 5/20/99 | N/A | CS | KK N/A |
| F | REVISED PER ECN 5817 | 7/17/99 | N/A | CS | KK N/A |
| F1 | REVISED PER ECN 6369 | 4/2/02 | N/A | CS | KK N/A |
| F2 | REVISED PER ECN 7118 | 3/15/03 | N/A | CS | KK N/A |
| F3 | REVISED PER ECN 9876 | 10/11/04 | MY | JP | KK TS |
| G | REVISED PER ECN 18450 | 1/20/04 | N/A | BS | JG KE |
| H | REVISED PER ECN 19838 | 1/17/07 | N/A | BS | JG KE |
| H1 | REVISED PER ECN 23036 | 6/5/09 | N/A | BS | MS NF |
| H2 | REVISED PER ECN 23561 | 10/28/09 | N/A | BS | MS NF |

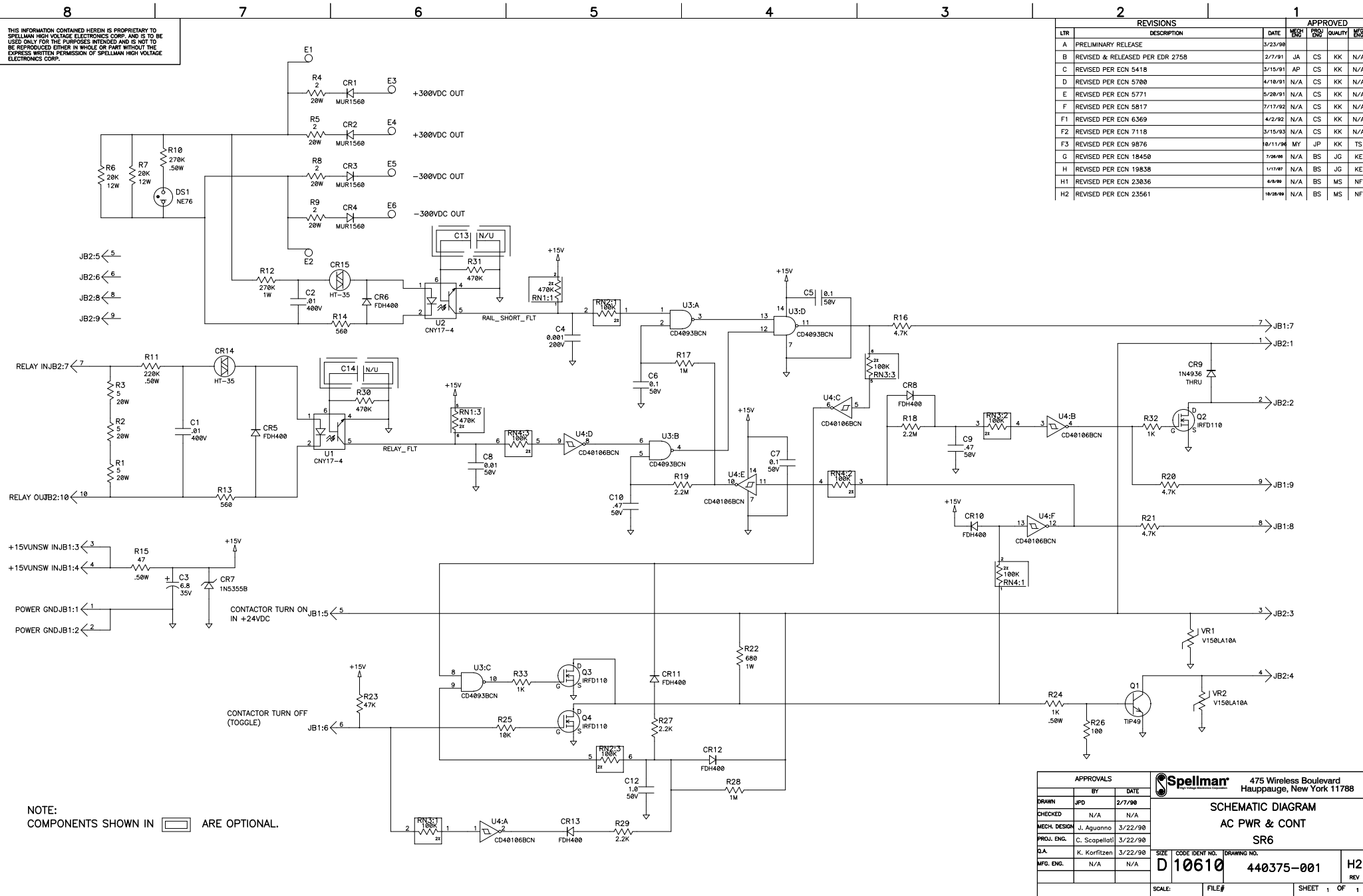

NOTE: COMPONENTS SHOWN IN  ARE OPTIONAL.

| APPROVALS | | | Spellman | | 475 Wireless Boulevard Hauppauge, New York 11788 | |
|--------------|----------------|---------|-------------------|--|---|--|
| DRAWN | BY | DATE | SCHEMATIC DIAGRAM | | | |
| JPD | | 2/7/98 | AC PWR & CONT | | | |
| CHECKED | N/A | N/A | SR6 | | | |
| MECH. DESIGN | J. Agunno | 3/22/98 | D 10610 | | | |
| PROJ. ENG. | C. Scappellati | 3/22/98 | 440375-001 | | | |
| D.A. | K. Korfitzen | 3/22/98 | H2 | | | |
| MFG. ENG. | N/A | N/A | REV | | | |

THIS INFORMATION CONTAINED HEREIN IS PROPRIETARY TO SPELLMAN HIGH VOLTAGE ELECTRONICS CORP. AND IS TO BE USED ONLY FOR THE PURPOSES INTENDED AND IS NOT TO BE REPRODUCED EITHER IN WHOLE OR PART WITHOUT THE EXPRESS WRITTEN PERMISSION OF SPELLMAN HIGH VOLTAGE ELECTRONICS CORP.

| REVISIONS | | APPROVED | | | | |
|-----------|---------------------------------|----------|-------------|----------|---------|--------|
| LTR | DESCRIPTION | DATE | MECH DESIGN | PROJ ENG | QUALITY | MG ENG |
| A | PRELIMINARY RELEASE | 3/23/90 | N/A | N/A | N/A | N/A |
| B | REVISED & RELEASED PER EDR 2758 | 2/7/91 | A.P. | B.V. | K.K. | N/A |
| B1 | REVISED PER ECN 10387 | 3/18/97 | A.P. | B.V. | A.P. | L.B. |

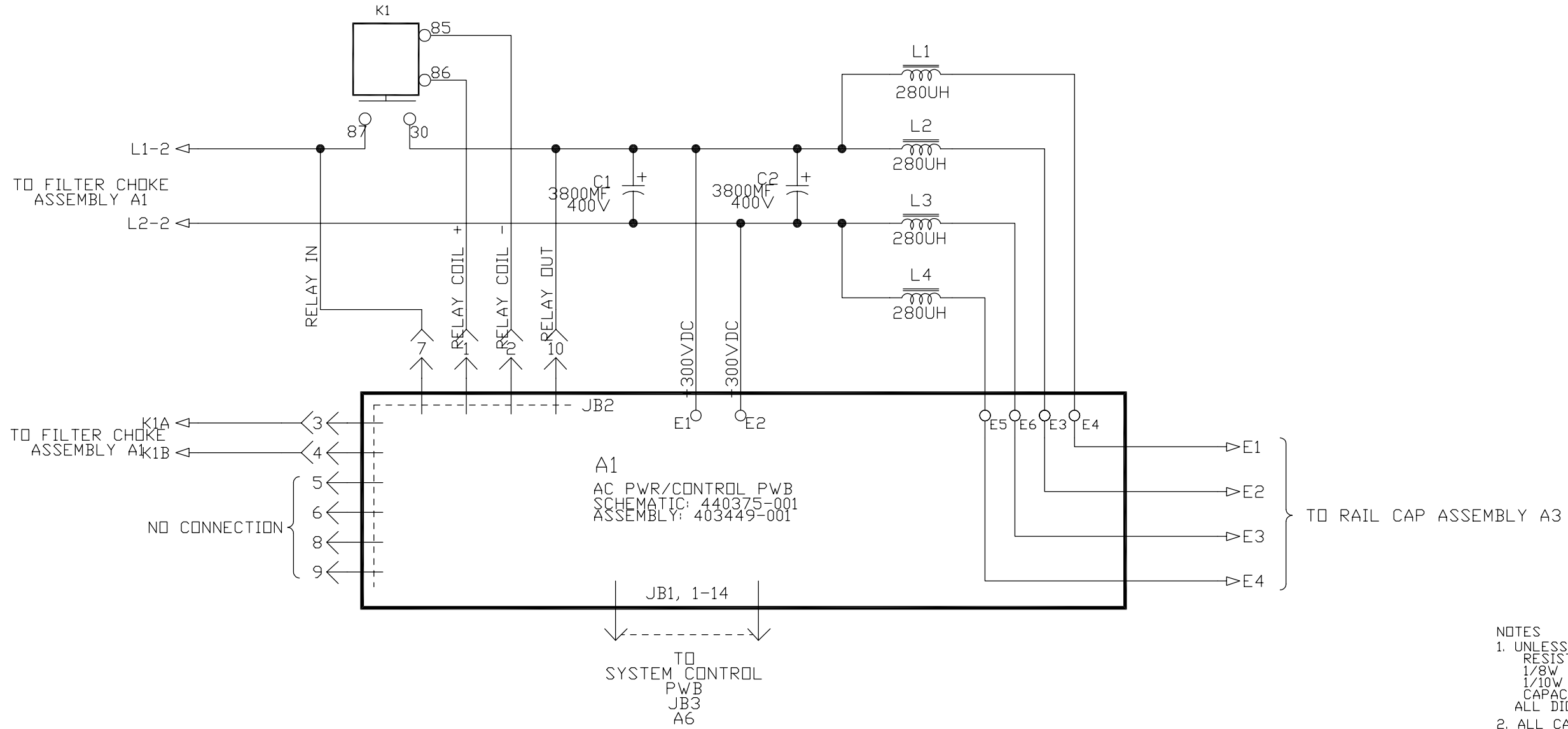

- NOTES
- UNLESS OTHERWISE SPECIFIED:
RESISTORS ARE IN OHMS, 1/4W.
1/8W RESISTORS ARE RN, 1%
1/10W RESISTORS ARE RN, 0.1%
CAPACITORS ARE IN MICROFARADS.
ALL DIODES ARE FDH400.
 - ALL CAPACITORS WITH UNMARKED VOLTAGES ARE 50 VOLT MIN.

| UNLESS OTHERWISE SPECIFIED DIMENSIONS ARE IN INCHES | | | APPROVALS | | | Spellman 475 Wireless Boulevard Hauppauge, New York 11788 | | |
|---|----------|--------|---------------------------------|--------|---------|---|-------------|-----|
| FRACTIONS | DECIMALS | ANGLES | BY | DATE | SIZE | CODE IDENT NO. | DRAWING NO. | REV |
| ± | .XX ± | ± | DRAWN | J.P.D. | 3/3/90 | D | 10610 | B1 |
| | .XXX | | CHECKED | N/A | | | 440376-001 | |
| | | | MECH. DESIGN | J.A. | 3/22/90 | | | |
| | | | PROJ. ENG. | B.V. | 3/22/90 | | | |
| | | | Q.A. | K.K. | 3/22/90 | | | |
| | | | MFG. ENG. | L.B. | 3/18/97 | | | |
| MATERIAL | | | BREAK ALL SHARP EDGES & CORNERS | | | SCALE: NONE FILE# | | |
| FINISH | | | DO NOT SCALE DRAWING | | | SHEET 1 OF 1 | | |

| PART NO. | NEXT ASSY | USED ON |
|-------------|------------|---------|
| 440376-001 | 403476-001 | SR6 |
| APPLICATION | | |

THIS INFORMATION CONTAINED HEREIN IS PROPRIETARY TO SPELLMAN HIGH VOLTAGE ELECTRONICS CORP. AND IS TO BE USED ONLY FOR THE PURPOSES INTENDED AND IS NOT TO BE REPRODUCED EITHER IN WHOLE OR PART WITHOUT THE EXPRESS WRITTEN PERMISSION OF SPELLMAN HIGH VOLTAGE ELECTRONICS CORP.

REVISIONS

APPROVED

| LTR | DESCRIPTION | DATE | MECH DESIGN | PROJ ENG | QUALITY | MFG ENG |
|-----|-----------------------|---------|-------------|----------|---------|---------|
| A | PRELIMINARY RELEASE | 3/23/90 | N/A | N/A | N/A | N/A |
| B | RELEASED PER EDR 2758 | 2/7/91 | J.P.D. | C.S. | K.K. | N/A |

DESCRIPTION OF HOLES

| SYM | DESCRIPTION | QTY |
|-----|-------------|-----|
|-----|-------------|-----|

C1 THRU C8
20MF 200V

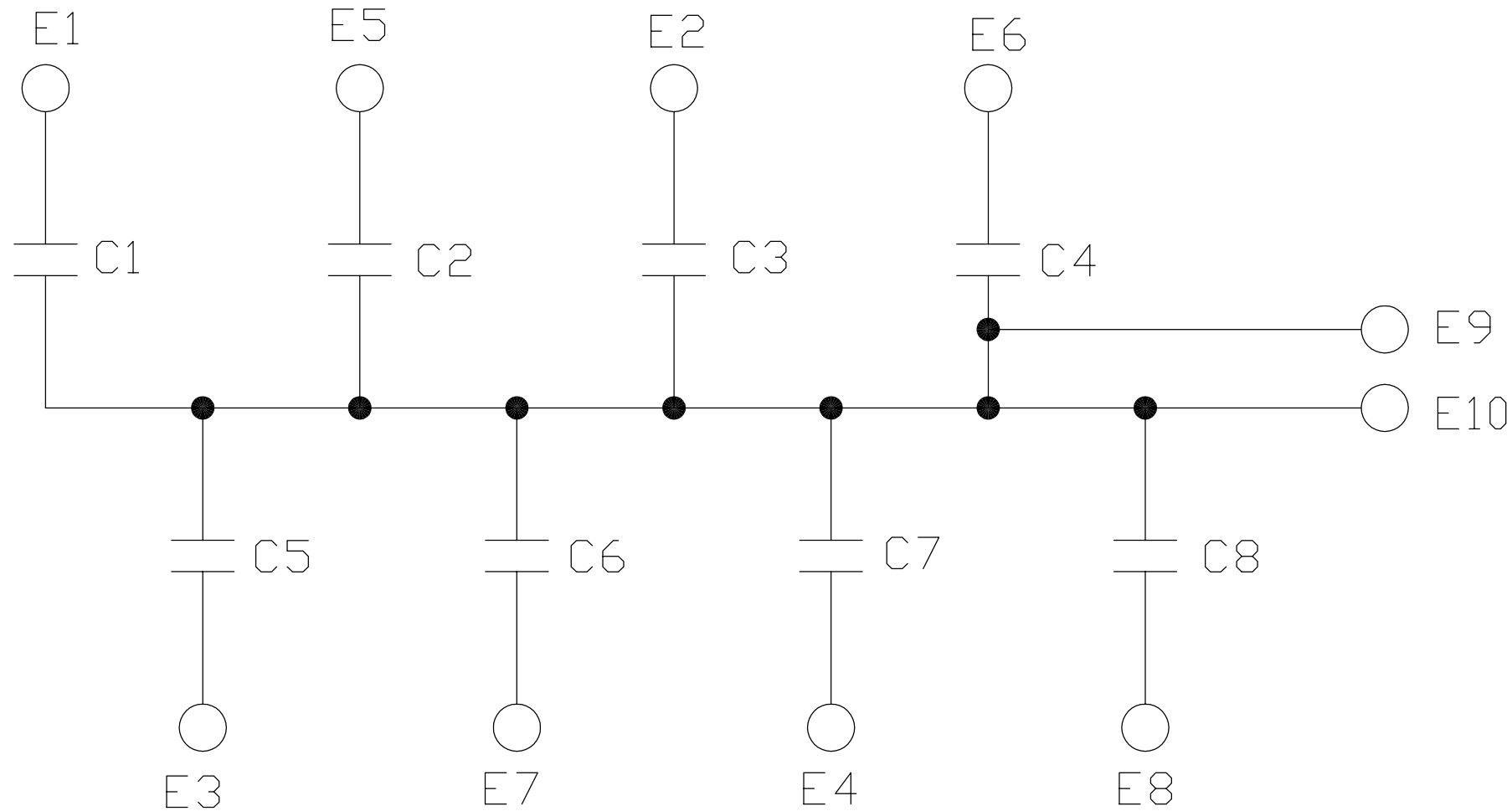

| UNLESS OTHERWISE SPECIFIED DIMENSIONS ARE IN INCHES TOLERANCES ARE: FRACTIONS DECIMALS ANGLES ± .XX ± ± .XXX ± | APPROVALS | DATE |
|---|------------------------|---------|
| MATERIAL | DRAWN <i>J.P.D.</i> | 3/3/90 |
| | CHECKED <i>N/A</i> | N/A |
| FINISH | DESIGN <i>J.P.D.</i> | 3/22/90 |
| | PROJ. ENG. <i>C.S.</i> | 3/22/90 |
| DO NOT SCALE DRAWING | Q.A. <i>K.K.</i> | 3/22/90 |
| | MFG. ENG. <i>N/A</i> | 3/22/90 |

Spellman High Voltage Electronics Corporation
475 Wireless Boulevard
Hauppauge, New York 11788

**SCHEMATIC DIAGRAM
RAIL CAP ASSEMBLY
SR6**

| | | | |
|------|----------------|-------------|-----|
| SIZE | CODE IDENT NO. | DRAWING NO. | REV |
| B | 10610 | 240048-001 | B |

SCALE: NONE FILE# SHEET 1 OF 1

| | | |
|-------------|------------|---------|
| 240048-001 | 403460-001 | SR6 |
| PART NO. | NEXT ASSY | USED ON |
| APPLICATION | | |

THIS INFORMATION CONTAINED HEREIN IS PROPRIETARY TO SPELLMAN HIGH VOLTAGE ELECTRONICS CORP. AND IS TO BE USED ONLY FOR THE PURPOSES INTENDED AND IS NOT TO BE REPRODUCED EITHER IN WHOLE OR PART WITHOUT THE EXPRESS WRITTEN PERMISSION OF SPELLMAN HIGH VOLTAGE ELECTRONICS CORP.

| REVISIONS | | | APPROVED | | | |
|-----------|----------------------------------|----------|----------|----------|---------|---------|
| LTR | DESCRIPTION | DATE | MECH ENG | PROJ ENG | QUALITY | MFG ENG |
| A | PRELIMINARY RELEASE | 3/23/90 | N/A | N/A | K.K. | N/A |
| B | REVISED & RELEASED PER EDR 2758 | 2/7/91 | F.A. | B.S. | K.K. | N/A |
| C | REVISED PER ECN 6205 | 3/23/92 | F.A. | B.S. | K.K. | N/A |
| C1 | REVISED PER ECN 7236 DWG. UPDATE | 7/23/93 | M.H. | B.S. | K.K. | N/A |
| D | REVISED PER ECN 9685 | 9/13/96 | M.Y. | F.B.S. | K.K. | F.S. |
| D1 | REVISED PER ECN 9876 | 10/11/96 | M.Y. | F.B.S. | K.K. | F.S. |

DESCRIPTION OF HOLES

| SYM | DESCRIPTION | QTY |
|-----|-------------|-----|
| | | |

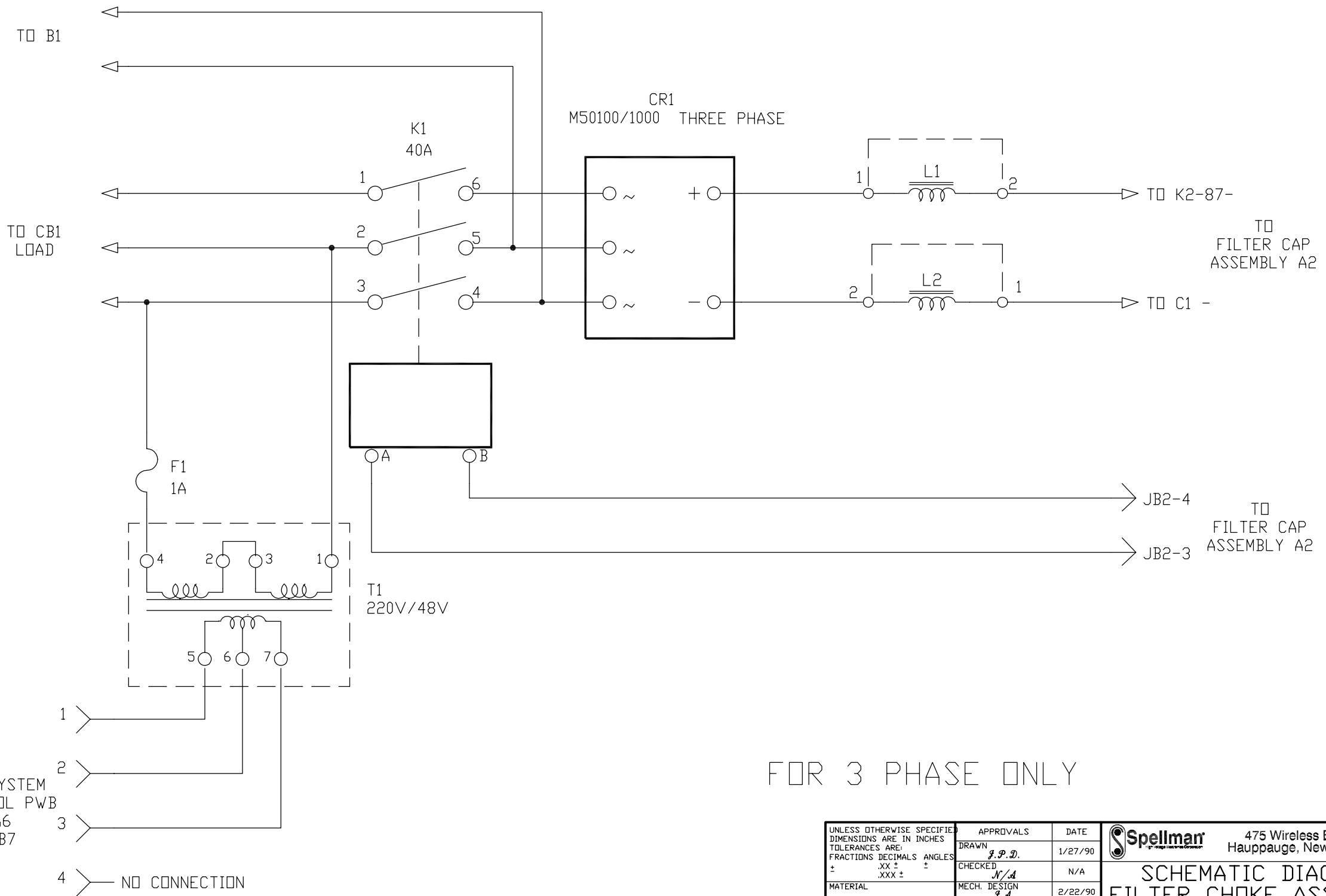

FOR 3 PHASE ONLY

| | | |
|-------------|------------|---------|
| 340198-001 | 403477-001 | SR6 |
| PART NO. | NEXT ASSY | USED ON |
| APPLICATION | | |

| | | |
|--|---------------------------------|-------------|
| UNLESS OTHERWISE SPECIFIED DIMENSIONS ARE IN INCHES TOLERANCES ARE: FRACTIONS DECIMALS ANGLES ± .XX ± .XXX ± | APPROVALS | DATE |
| | DRAWN <i>F.P.D.</i> | 1/27/90 |
| | CHECKED <i>N/A</i> | N/A |
| | MECH. DESIGN <i>F.A.</i> | 2/22/90 |
| | PRD.J. ENG. <i>B.S.</i> | 2/22/90 |
| MATERIAL | Q.A. <i>K.K.</i> | 3/22/90 |
| FINISH | MFG. ENG. <i>N/A</i> | N/A |
| DO NOT SCALE DRAWING | BREAK ALL SHARP EDGES & CORNERS | SCALE: NONE |

Spellman 475 Wireless Boulevard
Hauppauge, New York 11788

**SCHEMATIC DIAGRAM
FILTER CHOKE ASSEMBLY
SR6**

| | | | |
|---------|----------------|-------------|-----|
| SIZE | CODE IDENT NO. | DRAWING NO. | REV |
| C 10610 | 340198-001 | D1 | D1 |

SHEET 1 OF 2

THIS INFORMATION CONTAINED HEREIN IS PROPRIETARY TO SPELLMAN HIGH VOLTAGE ELECTRONICS CORP. AND IS TO BE USED ONLY FOR THE PURPOSES INTENDED AND IS NOT TO BE REPRODUCED EITHER IN WHOLE OR PART WITHOUT THE EXPRESS WRITTEN PERMISSION OF SPELLMAN HIGH VOLTAGE ELECTRONICS CORP.

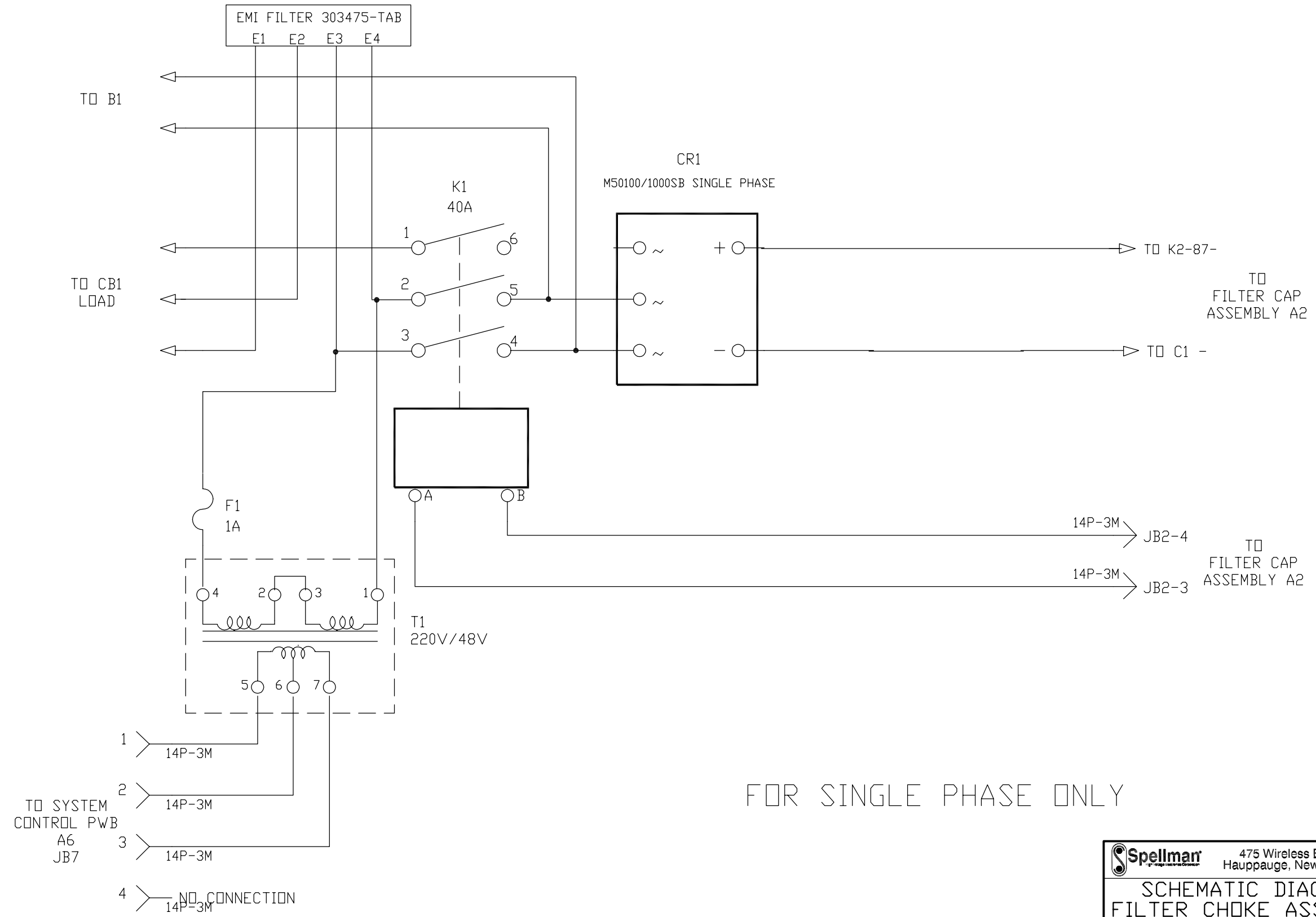

FOR SINGLE PHASE ONLY

Spellman 475 Wireless Boulevard
Hauppauge, New York 11788

SCHEMATIC DIAGRAM
FILTER CHOKES ASSEMBLY
SR6

| | | | |
|-------------|----------------|--------------|-----|
| SIZE | CODE IDENT NO. | DRAWING NO. | REV |
| C | 10610 | 340198-001 | D1 |
| SCALE: NONE | FILE# | SHEET 2 OF 2 | |

THIS INFORMATION CONTAINED HEREIN IS PROPRIETARY TO SPELLMAN HIGH VOLTAGE ELECTRONICS CORP. AND IS TO BE USED ONLY FOR THE PURPOSES INTENDED AND IS NOT TO BE REPRODUCED EITHER IN WHOLE OR PART WITHOUT THE EXPRESS WRITTEN PERMISSION OF SPELLMAN HIGH VOLTAGE ELECTRONICS CORP.

| REVISIONS | | | | | APPROVED | |
|-----------|---------------------------|---------|--------|------|----------|-----|
| LTR | DESCRIPTION | DATE | DESIGN | TRSP | QUALITY | ENG |
| A | RELEASED PER EDR 5186 | 8/21/00 | J/A | J/K | J/K | J/K |
| A1 | REVISED PER EDR NO. 16879 | 5/14/03 | J/A | J/K | J/K | J/K |

| DESCRIPTION OF HOLES | | |
|----------------------|-------------|-----|
| SYM | DESCRIPTION | QTY |
| | | |

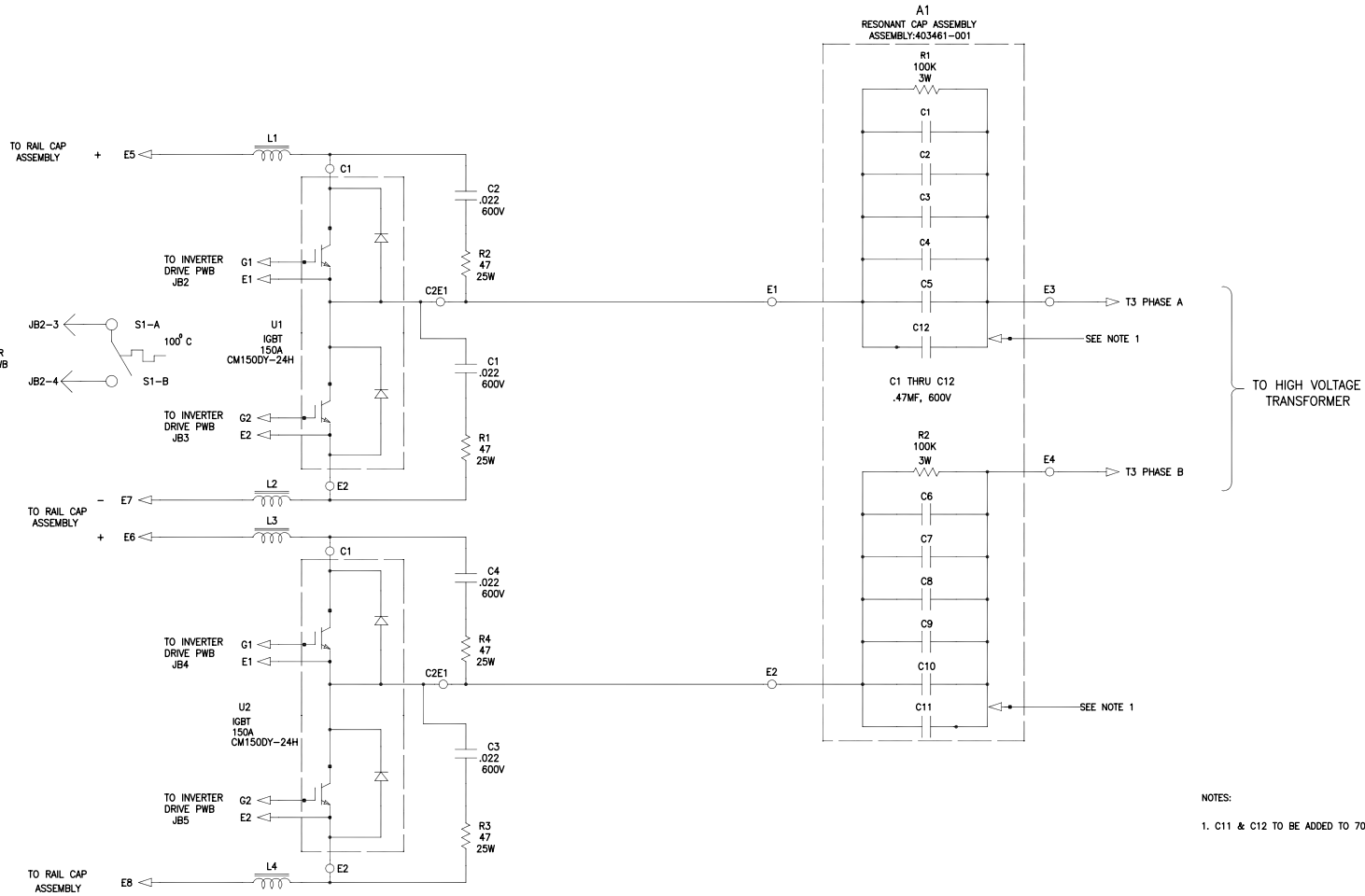

NOTES:
1. C11 & C12 TO BE ADDED TO 70-120KV UNITS ONLY.

| UNLESS OTHERWISE SPECIFIED TOLERANCES ARE IN INCHES | | | APPROVALS | | 475 WIRELESS BLVD. HAUPPAUGE, NEW YORK 11788 |
|---|--------------------|--------|-------------|----------------|--|
| FRACTIONS | DECIMALS | ANGLES | BY | DATE | |
| ± | XX.X .01 .001 .005 | ° | | | |
| MATERIAL | | | CHECKED | J/A | 5/24/00 |
| FINISH | | | MECH. DESGN | J/A | 5/24/00 |
| | | | PROJ. ENG. | J. Spindlerman | 5/24/00 |
| | | | Q.A. | J. Spindlerman | 5/24/00 |
| | | | MFG. ENG. | J. Spindlerman | 5/24/00 |

| | | |
|-------------|-----------|---------|
| 440369-002 | | SR6 |
| PART NO. | NEXT ASSY | USED ON |
| | | |
| APPLICATION | | |

| | | | | |
|----------------------|---------------------------------|-------------|-------|--------------|
| DO NOT SCALE DRAWING | BREAK ALL SHARP EDGES & CORNERS | SCALE: NONE | FILE# | SHEET 1 OF 1 |
|----------------------|---------------------------------|-------------|-------|--------------|

| | | | |
|--|----------------|-------------|-----|
| Schematic Diagram IGBT Inverter Assembly SR6 | | | |
| SIZE | CODE IDENT NO. | DRAWING NO. | REV |
| D | 10610 | 440369-002 | A1 |

THIS INFORMATION CONTAINED HEREIN IS PROPRIETARY TO SPELLMAN HIGH VOLTAGE ELECTRONICS CORP. AND IS TO BE USED ONLY FOR THE PURPOSES INTENDED AND IS NOT TO BE REPRODUCED EITHER IN WHOLE OR PART WITHOUT THE EXPRESS WRITTEN PERMISSION OF SPELLMAN HIGH VOLTAGE ELECTRONICS CORP.

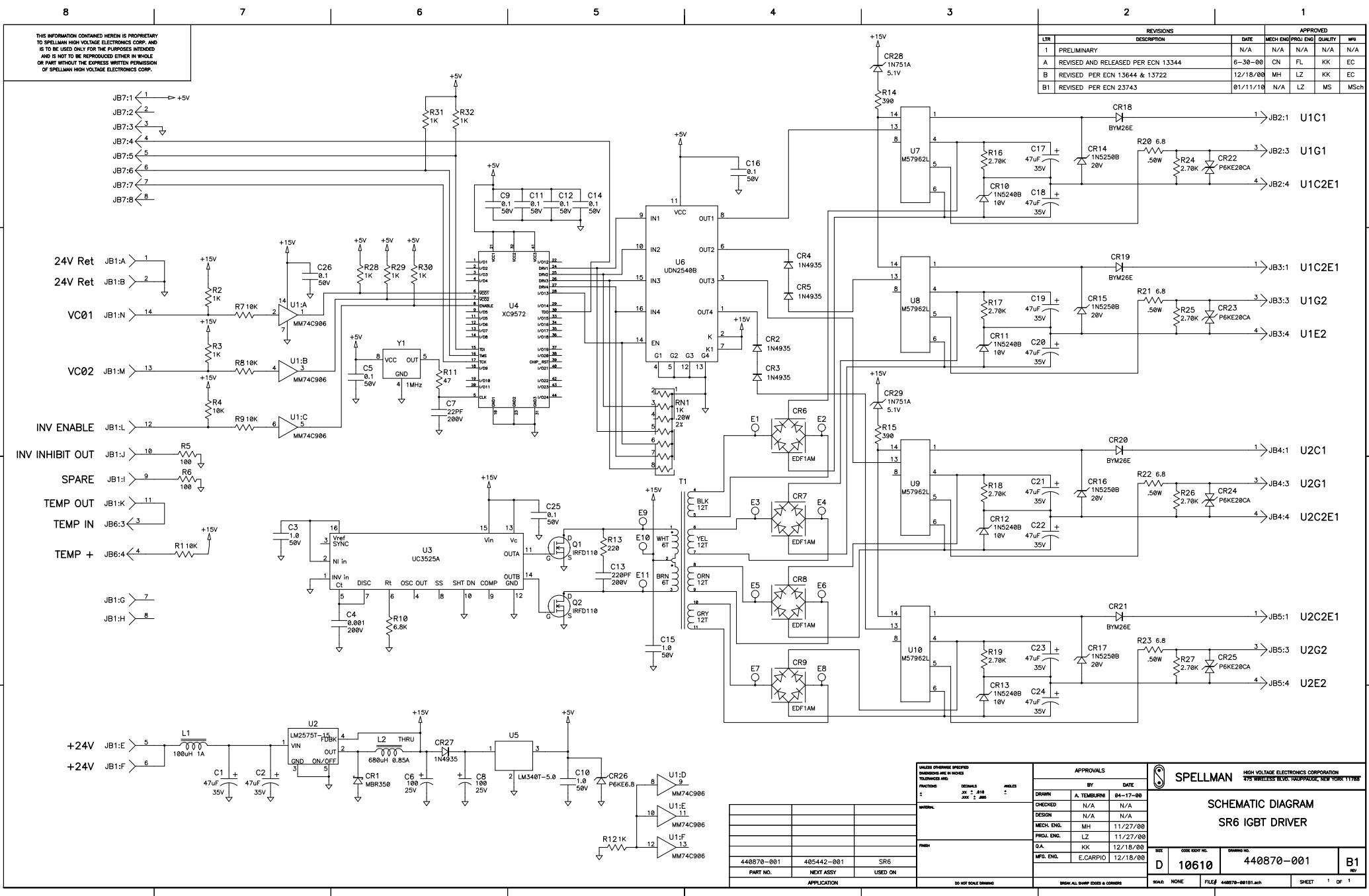

| REVISIONS | | | | |
|-----------|------------------------------------|----------|-----------|----------|
| LTR | DESCRIPTION | DATE | MECH ENGR | APPROVED |
| 1 | PRELIMINARY | N/A | N/A | N/A |
| A | REVISED AND RELEASED PER ECN 13344 | 6-30-00 | CN | FL |
| B | REVISED PER ECN 13644 & 13722 | 12/18/00 | MH | LZ |
| B1 | REVISED PER ECN 23743 | 01/11/01 | N/A | LZ |

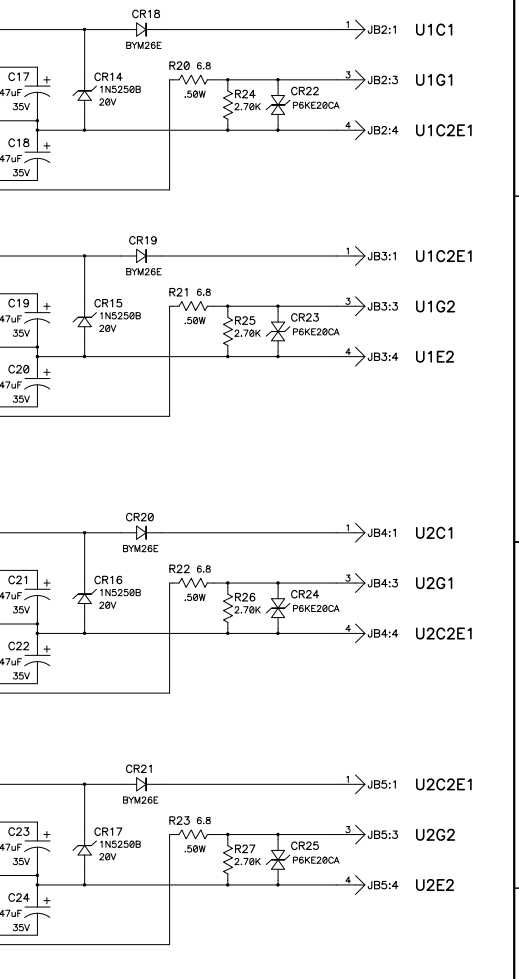

UNLESS OTHERWISE SPECIFIED DIMENSIONS ARE IN INCHES TOLERANCES ARE:

FRACTIONS DECIMALS ANGLES

INCHES .005 .010 .015

APPROVALS

BY: A. TEMERINI DATE: 04-17-00

CHECKED: N/A DATE: N/A

DESIGN: N/A DATE: N/A

MECH. ENG.: MH DATE: 11/27/00

PROJ. ENG.: LZ DATE: 11/27/00

D.A.: KK DATE: 12/18/00

MFG. ENG.: E.CARPIO DATE: 12/18/00

SPELLMAN HIGH VOLTAGE ELECTRONICS CORPORATION
370 WIRELESS BLVD. PALM SPRING, NEW YORK 11788

SCHEMATIC DIAGRAM
SR6 IGBT DRIVER

DRAWN: N/A
DATE: N/A

DESIGN: N/A
DATE: N/A

MECH. ENG.: MH
DATE: 11/27/00

PROJ. ENG.: LZ
DATE: 11/27/00

D.A.: KK
DATE: 12/18/00

MFG. ENG.: E.CARPIO
DATE: 12/18/00

CODE: 10610
DRAWING NO.: 440870-001

SCALE: NONE
FILE: 440870-001B1.dwg

SHEET 1 OF 1

| PART NO. | NEXT ASSY | USED ON |
|------------|------------|---------|
| 440870-001 | 405442-001 | SR6 |
| | | |
| | | |
| | | |

THIS INFORMATION CONTAINED HEREIN IS PROPRIETARY TO SPELLMAN HIGH VOLTAGE ELECTRONICS CORP. AND IS TO BE USED ONLY FOR THE PURPOSES INTENDED AND IS NOT TO BE REPRODUCED EITHER IN WHOLE OR PART WITHOUT THE EXPRESS WRITTEN PERMISSION OF SPELLMAN HIGH VOLTAGE ELECTRONICS CORP.

| SYM | DESCRIPTION | QTY |
|-----|-------------|-----|
|-----|-------------|-----|

| REVISIONS | | | | APPROVED | | |
|-----------|--------------------------------------|----------|-------------|----------|---------|---------|
| LTR | DESCRIPTION | DATE | MECH DESIGN | PROJ ENG | QUALITY | WFS ENG |
| A | PRELIMINARY ENG RELEASE | 3/5/90 | J.A. | B.S. | X.X. | J.S. |
| B | EXTENSIVELY REVISED | 8/7/90 | J.A. | B.S. | X.X. | N/A |
| C | REVISED PER ECN'S 5566&5700 SHTS 3&5 | 2/25/91 | A.P. | B.S. | X.X. | N/A |
| D | REVISED PER ECN'S 5747 & 5856 | 5/13/91 | J.A. | B.S. | X.X. | N/A |
| E | REVISED PER ECN 6205 | 3/25/92 | J.A. | B.S. | X.X. | N/A |
| E1 | REVISED PER ECN 6444 | 4/23/92 | J.A. | B.S. | X.X. | N/A |
| H | REVISED PER ECN 6468 | 9/4/92 | J.A. | B.S. | X.X. | N/A |
| H1 | REVISED PER ECN 6720 BOM MOD. | 9/4/92 | N/A | B.S. | X.X. | N/A |
| H1 | CLERICAL CHANGE ONLY NO ECN REQ. | 10/22/92 | J.A. | B.S. | X.X. | N/A |
| H2 | REVISED PER ECN 7188 | 4/16/93 | M.H. | B.S. | X.X. | N/A |
| H3 | REVISED PER ECN 8899 | 8/4/95 | M.H. | B.S. | X.X. | S.S. |
| H4 | REVISED PER ECN 9876 | 10/11/98 | M.H. | B.S. | X.X. | S.S. |
| J | REVISED PER ECN 11528 | 5/22/98 | X.X. | B.S. | X.X. | S.S. |
| J1 | REVISED PER ECN 13269 | 5/31/00 | X.X. | A.P. | X.X. | S.S. |
| K | REVISED PER ECN 18450 | 7/26/06 | N/A | B.S. | J.S. | X.S. |
| K1 | REVISED PER ECN NO. 19594 | 12/4/06 | N/A | R.D. | J.S. | X.S. |
| L | REVISED PER ECN NO. 20032 | 5/16/07 | N/A | B.S. | J.S. | M.S. |
| L1 | REVISED PER ECN NO. 20351 | 6/6/07 | N/A | B.S. | J.S. | X.S. |
| L2 | REVISED PER ECN NO. 20692 | 8/27/07 | M.H. | B.S. | J.S. | M.S. |
| L3 | REVISED PER ECN NO. 20939 | 11/15/07 | M.H. | B.S. | M.S. | S.S. |
| L4 | REVISED PER ECN NO. 21277 | 1/30/08 | N/A | B.S. | M.S. | M.S. |
| L5 | REVISED PER ECN NO. 21340 | 2/27/08 | N/A | B.S. | M.S. | M.S. |
| L6 | REVISED PER ECN NO. 21655 | 5/22/08 | N/A | B.S. | J.S. | M.S. |

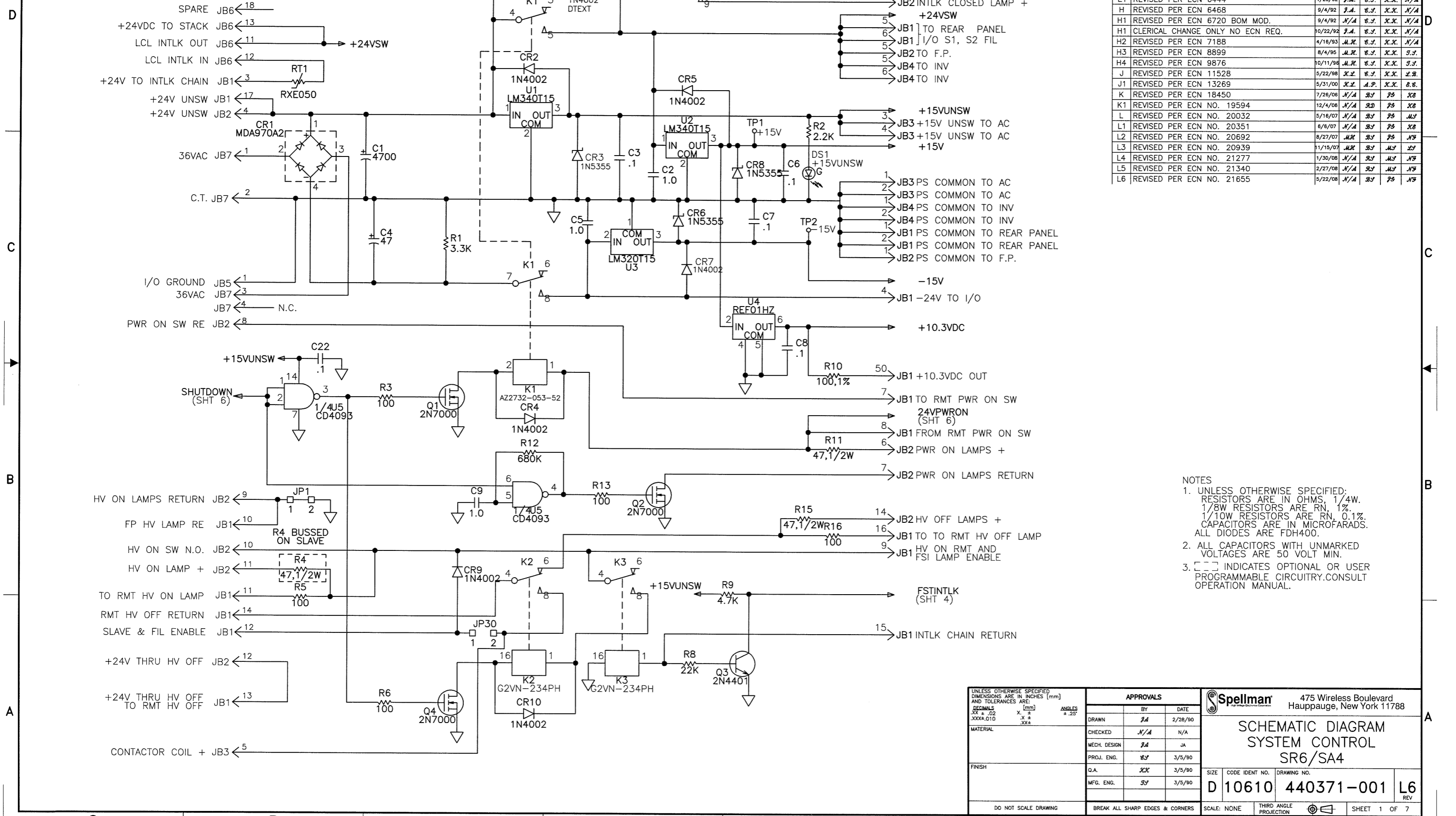

- NOTES
- UNLESS OTHERWISE SPECIFIED: RESISTORS ARE IN OHMS, 1/4W. 1/8W RESISTORS ARE RN, 1%. 1/10W RESISTORS ARE RN, 0.1%. CAPACITORS ARE IN MICROFARADS. ALL DIODES ARE FDH400.
 - ALL CAPACITORS WITH UNMARKED VOLTAGES ARE 50 VOLT MIN.
 - [] INDICATES OPTIONAL OR USER PROGRAMMABLE CIRCUITRY. CONSULT OPERATION MANUAL.

| | | | | | |
|--|--|---------------------------------|--|---|--|
| UNLESS OTHERWISE SPECIFIED DIMENSIONS ARE IN INCHES (mm) AND TOLERANCES ARE: DECIMALS [mm] ANGLES ± 25° XX ± .02 X ± .1 XXXX.010 X ± .XX± | | APPROVALS | | Spellman® 475 Wireless Boulevard Hauppauge, New York 11788 | |
| DRAWN J.A. 2/26/90 | | BY DATE | | SCHEMATIC DIAGRAM SYSTEM CONTROL SR6/SA4 | |
| CHECKED N/A N/A | | MECH. DESIGN J.A. JA | | | |
| PROJ. ENG. B.S. 3/5/90 | | Q.A. X.X. 3/5/90 | | | |
| MFG. ENG. J.S. 3/5/90 | | SIZE CODE IDENT NO. DRAWING NO. | | | |
| DO NOT SCALE DRAWING | | BREAK ALL SHARP EDGES & CORNERS | | | |

THIS INFORMATION CONTAINED HEREIN IS PROPRIETARY TO SPELLMAN HIGH VOLTAGE ELECTRONICS CORP. AND IS TO BE USED ONLY FOR THE PURPOSES INTENDED AND IS NOT TO BE REPRODUCED EITHER IN WHOLE OR PART WITHOUT THE EXPRESS WRITTEN PERMISSION OF SPELLMAN HIGH VOLTAGE ELECTRONICS CORP.

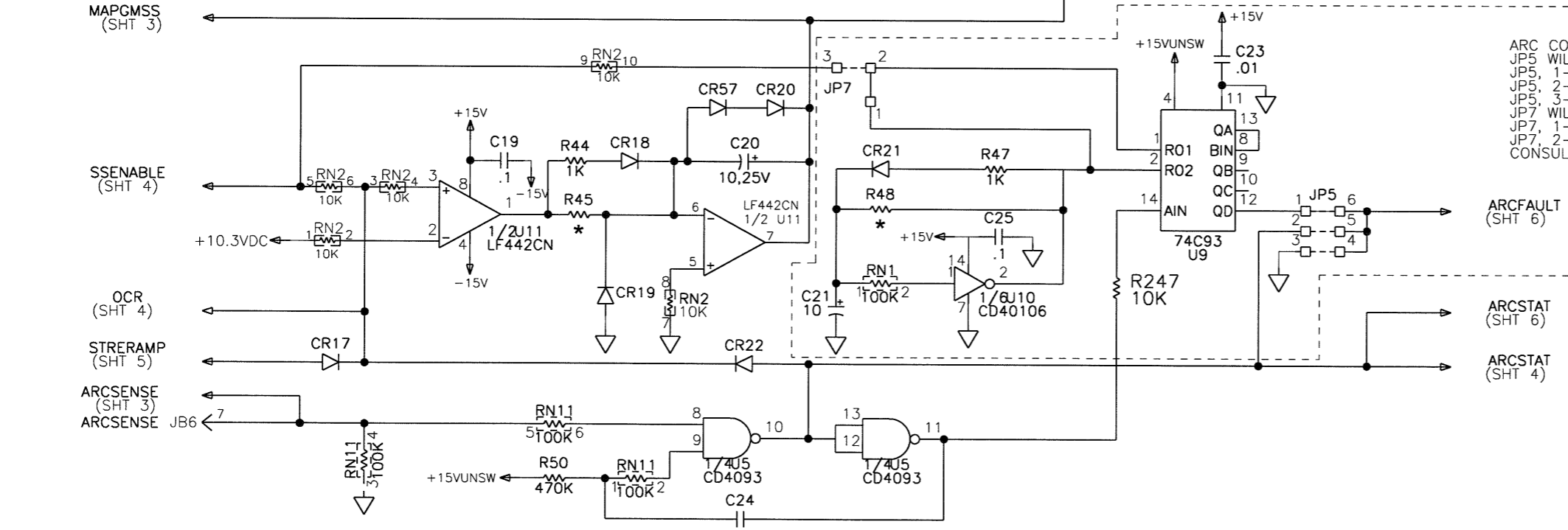
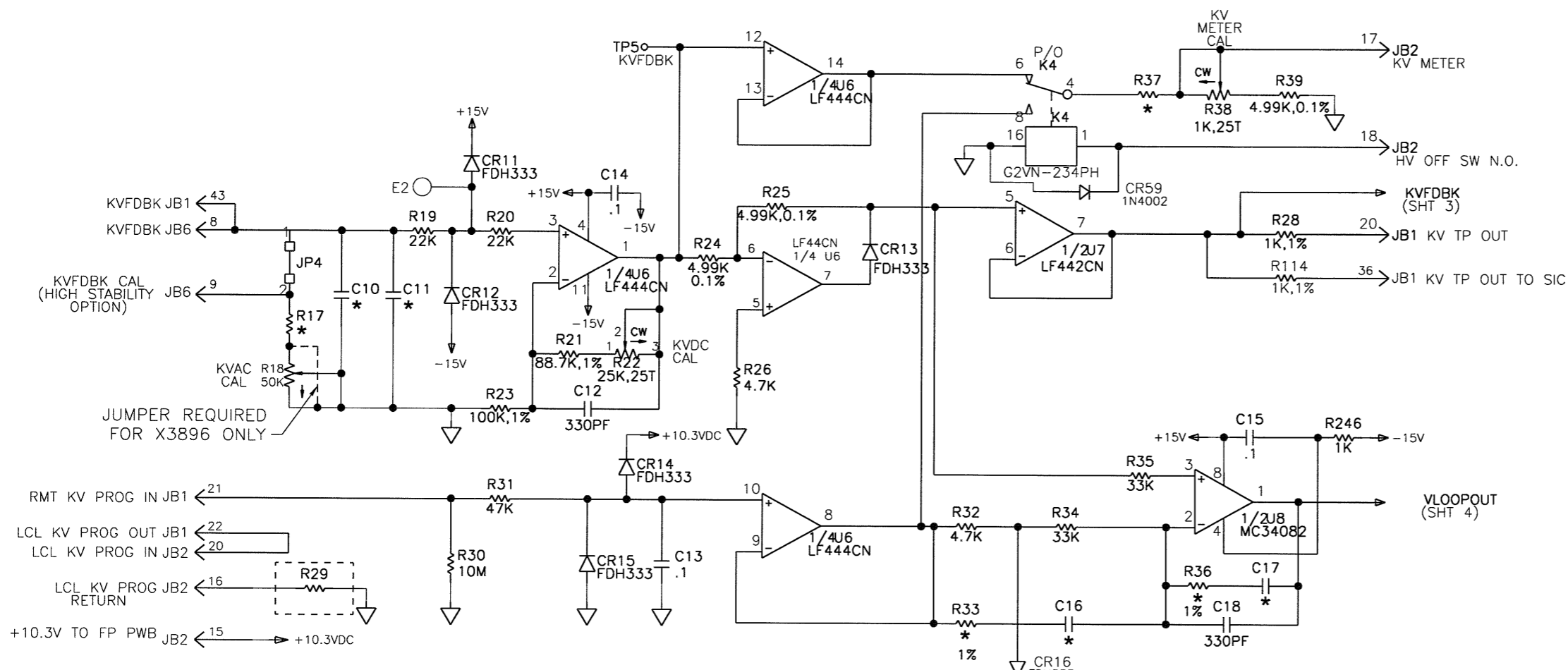

ARC COUNT AND ARCTRIP CIRCUITRY ARE CONTAINED WITHIN THIS BORDER.
 JP5 WILL PROGRAM THE ARC COUNT FEATURE.
 JP5, 1-6 WILL ALLOW 8 ARCS BEFORE SYSTEM SHUTDOWN.
 JP5, 2-5 WILL CAUSE SHUTDOWN ON 1 ARC.
 JP5, 3-4 WILL NOT CAUSE SYSTEM SHUTDOWN DURING ARCING.
 JP7 WILL PROGRAM THE ARC COUNT RESET.
 JP7, 1-2 WILL RESET THE ARC COUNT EVERY 20 SECONDS.
 JP7, 2-3 WILL NOT RESET THE ARC COUNT UNTIL SYSTEM SHUTDOWN.
 CONSULT OPERATION MANUAL FOR CIRCUIT OPERATION.

Spellman 475 Wireless Boulevard
 Hauppauge, New York 11788

SCHEMATIC DIAGRAM
SYSTEM CONTROL
SR6/SA4

| | | |
|------|----------------|-------------|
| SIZE | CODE IDENT NO. | DRAWING NO. |
| D | 10610 | 440371-001 |
| REV | L6 | |

SCALE: NONE THIRD ANGLE PROJECTION SHEET 2 OF 7

THIS INFORMATION CONTAINED HEREIN IS PROPRIETARY TO SPELLMAN HIGH VOLTAGE ELECTRONICS CORP. AND IS TO BE USED ONLY FOR THE PURPOSES INTENDED AND IS NOT TO BE REPRODUCED EITHER IN WHOLE OR PART WITHOUT THE EXPRESS WRITTEN PERMISSION OF SPELLMAN HIGH VOLTAGE ELECTRONICS CORP.

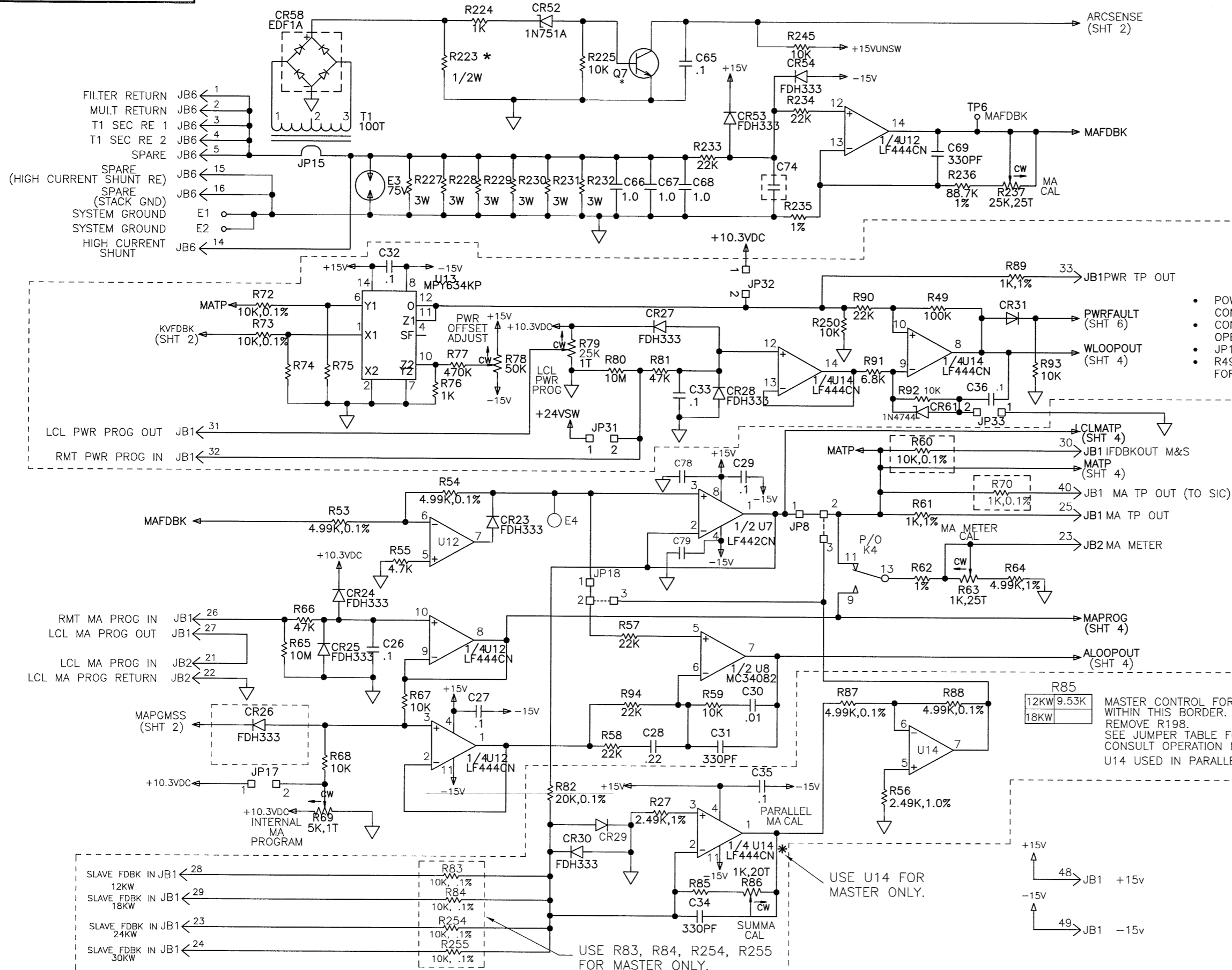

- POWER CONTROL OPTIONS CPC AND APT ARE CONTAINED WITHIN THIS BORDER.
- CONSULT OPERATION MANUAL FOR CIRCUIT OPERATION.
- JP14 IS REMOVED FOR CPC OPTION.
- R49, CR61, JP31, JP32 AND JP33 ARE REMOVED FOR CPC OPTION.

MASTER CONTROL FOR PARALLEL OPTIONS ARE CONTAINED WITHIN THIS BORDER.
 REMOVE R198.
 SEE JUMPER TABLE FOR MASTER/SLAVE JUMPER CONFIGURATION.
 CONSULT OPERATION MANUAL FOR CIRCUIT OPERATION.
 U14 USED IN PARALLEL OPTION ONLY

USE R83, R84, R254, R255 FOR MASTER ONLY.

USE U14 FOR MASTER ONLY.

| | | | |
|---|------------------------|---|-----|
| | | 475 Wireless Boulevard Hauppauge, New York 11788 | |
| SCHEMATIC DIAGRAM SYSTEM CONTROL SR6/SA4 | | | |
| SIZE | CODE IDENT NO. | DRAWING NO. | |
| D | 10610 | 440371-001 | L6 |
| SCALE: NONE | THIRD ANGLE PROJECTION | SHEET 3 OF 7 | REV |

THIS INFORMATION CONTAINED HEREIN IS PROPRIETARY TO SPELLMAN HIGH VOLTAGE ELECTRONICS CORP. AND IS TO BE USED ONLY FOR THE PURPOSES INTENDED AND IS NOT TO BE REPRODUCED EITHER IN WHOLE OR PART WITHOUT THE EXPRESS WRITTEN PERMISSION OF SPELLMAN HIGH VOLTAGE ELECTRONICS CORP.

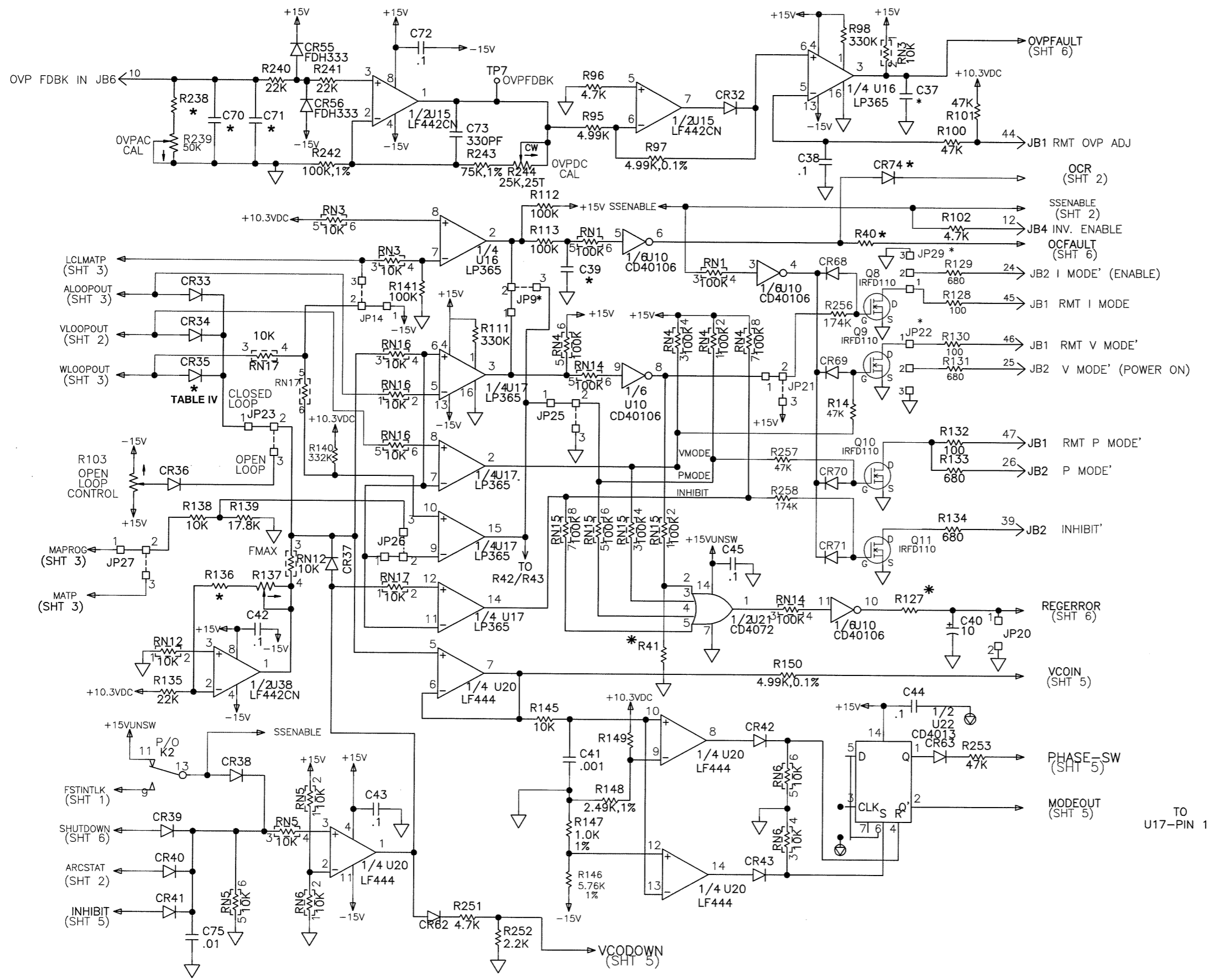

* FOR ADJUSTABLE OVERLOAD (AOL) OPTION
 JUMPER JP9, 1-2 AND REMOVE CR26, AND R198.
 FOR BFP OPTION JUMPER JP22-2,3 AND JP29-2,3

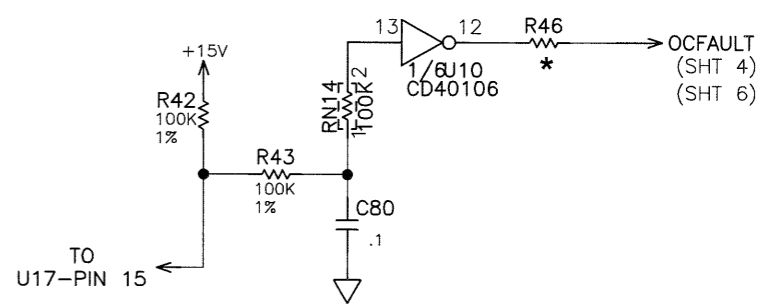

| | | | |
|---|------------------------|---|--------------|
| | | 475 Wireless Boulevard Hauppauge, New York 11788 | |
| SCHEMATIC DIAGRAM SYSTEM CONTROL SR6/SA4 | | | |
| SIZE | CODE IDENT NO. | DRAWING NO. | |
| D | 10610 | 440371-001 | L6 |
| SCALE: NONE | THIRD ANGLE PROJECTION | | SHEET 4 OF 7 |

THIS INFORMATION CONTAINED HEREIN IS PROPRIETARY TO SPELLMAN HIGH VOLTAGE ELECTRONICS CORP. AND IS TO BE USED ONLY FOR THE PURPOSES INTENDED AND IS NOT TO BE REPRODUCED EITHER IN WHOLE OR PART WITHOUT THE EXPRESS WRITTEN PERMISSION OF SPELLMAN HIGH VOLTAGE ELECTRONICS CORP.

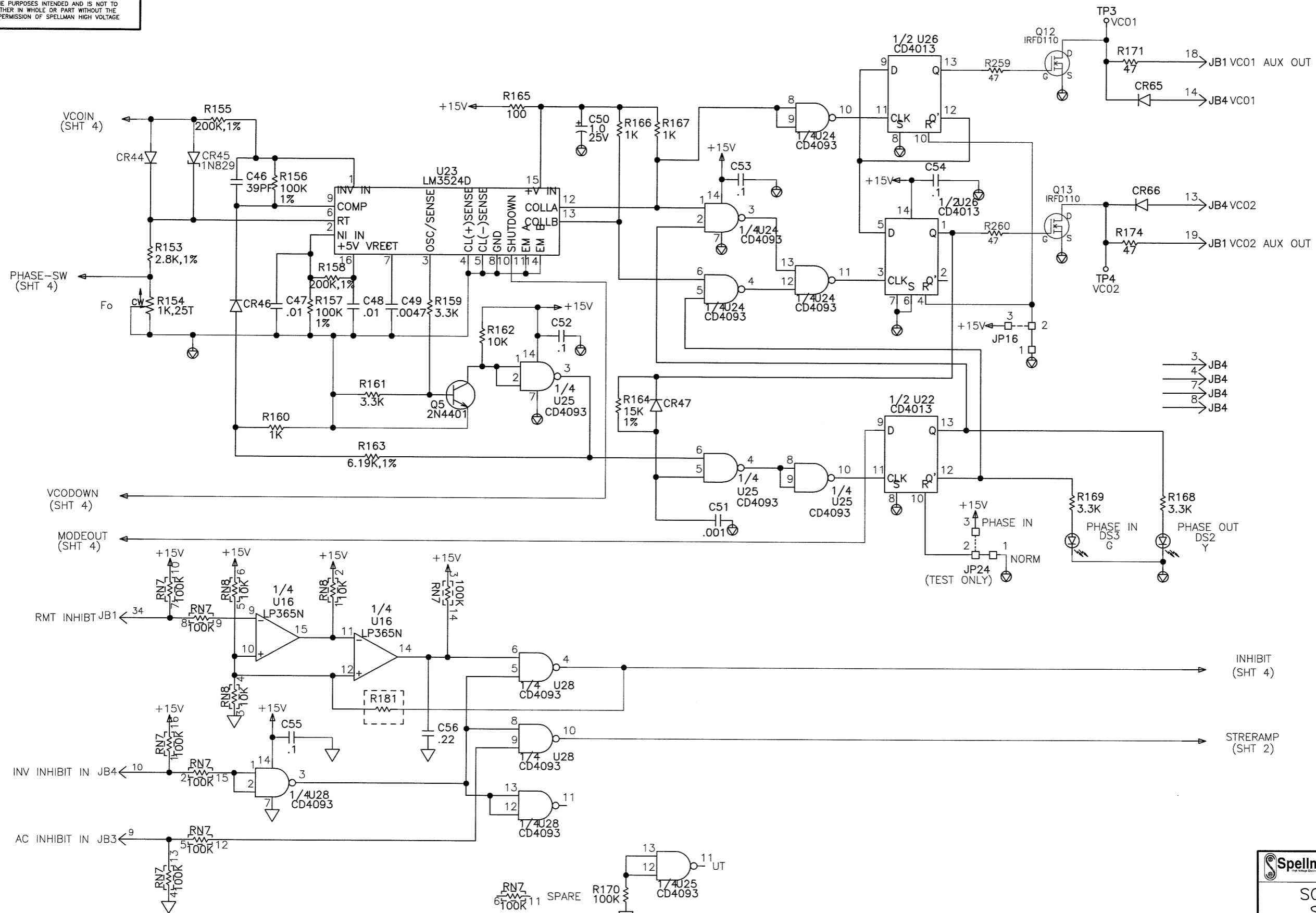

| | | | |
|---|------------------------|---|----|
| | | 475 Wireless Boulevard Hauppauge, New York 11788 | |
| SCHEMATIC DIAGRAM SYSTEM CONTROL SR6/SA4 | | | |
| SIZE | CODE IDENT NO. | DRAWING NO. | |
| D | 10610 | 440371-001 | L6 |
| SCALE: NONE | THIRD ANGLE PROJECTION | SHEET 5 OF 7 | |

THIS INFORMATION CONTAINED HEREIN IS PROPRIETARY TO SPELLMAN HIGH VOLTAGE ELECTRONICS CORP. AND IS TO BE USED ONLY FOR THE PURPOSES INTENDED AND IS NOT TO BE REPRODUCED EITHER IN WHOLE OR PART WITHOUT THE EXPRESS WRITTEN PERMISSION OF SPELLMAN HIGH VOLTAGE ELECTRONICS CORP.

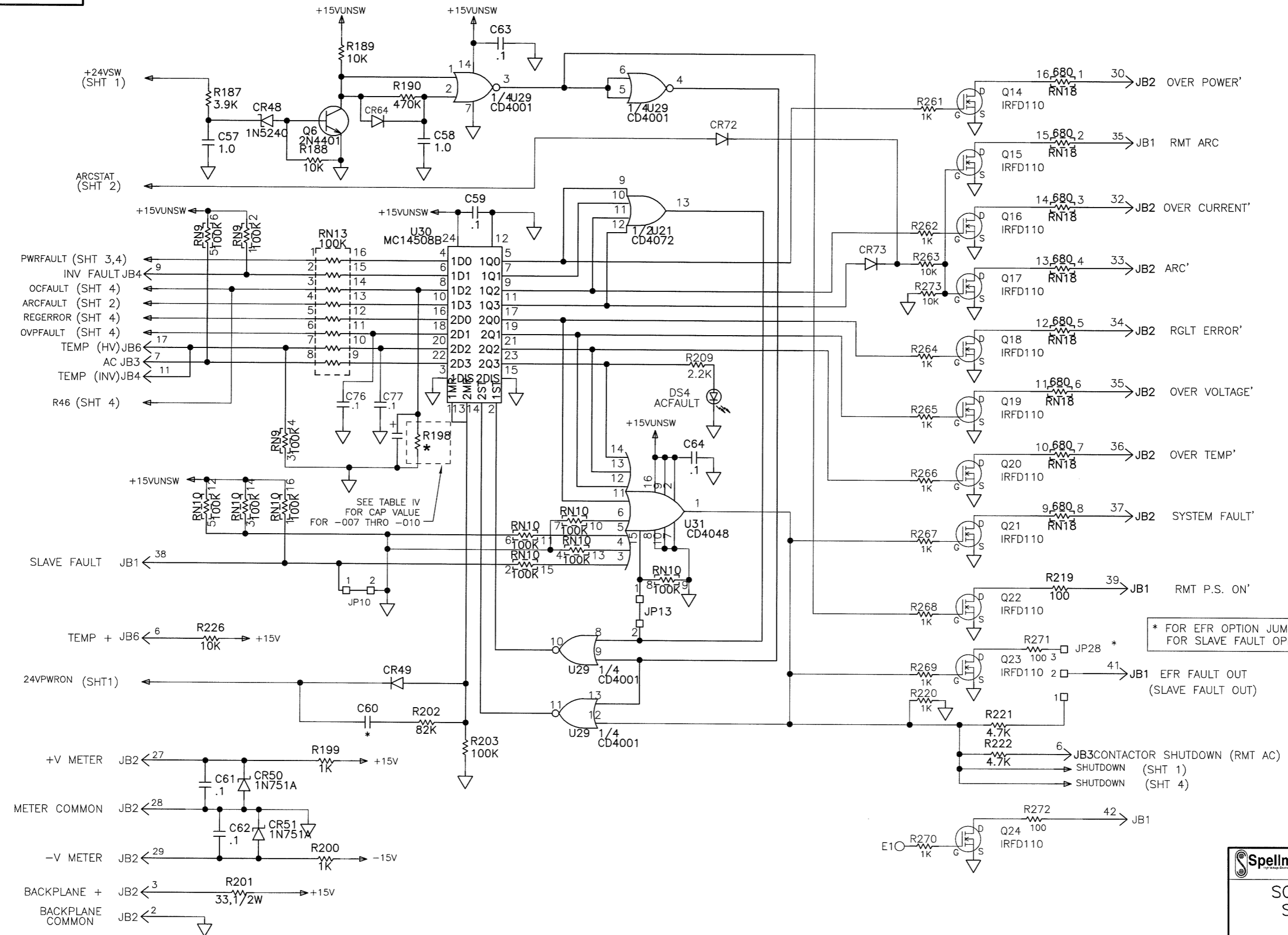

* FOR EFR OPTION JUMPER JP28-2,3
FOR SLAVE FAULT OPTION JUMPER JP28-1,2

Spellman 475 Wireless Boulevard
Hauppauge, New York 11788

SCHEMATIC DIAGRAM
SYSTEM CONTROL
SR6/SA4

| | | |
|------|----------------|-------------|
| SIZE | CODE IDENT NO. | DRAWING NO. |
| D | 10610 | 440371-001 |
| REV | L6 | |

SCALE: NONE THIRD ANGLE PROJECTION SHEET 6 OF 7

THIS INFORMATION CONTAINED HEREIN IS PROPRIETARY TO SPELLMAN HIGH VOLTAGE ELECTRONICS CORP. AND IS TO BE USED ONLY FOR THE PURPOSES INTENDED AND IS NOT TO BE REPRODUCED EITHER IN WHOLE OR PART WITHOUT THE EXPRESS WRITTEN PERMISSION OF SPELLMAN HIGH VOLTAGE ELECTRONICS CORP.

REVISIONS

| LTR | DESCRIPTION | DATE | MECH ENG | PROJ ENG | QUALITY | MFG ENG |
|-----|-----------------------|---------|----------|----------|---------|---------|
| A | RELEASED PER EDR 2758 | 2/13/91 | N/A | B.S. | K.K. | N/A |

APPROVED

DESCRIPTION OF HOLES

| SYM | DESCRIPTION | QTY |
|-----|-------------|-----|
| | | |

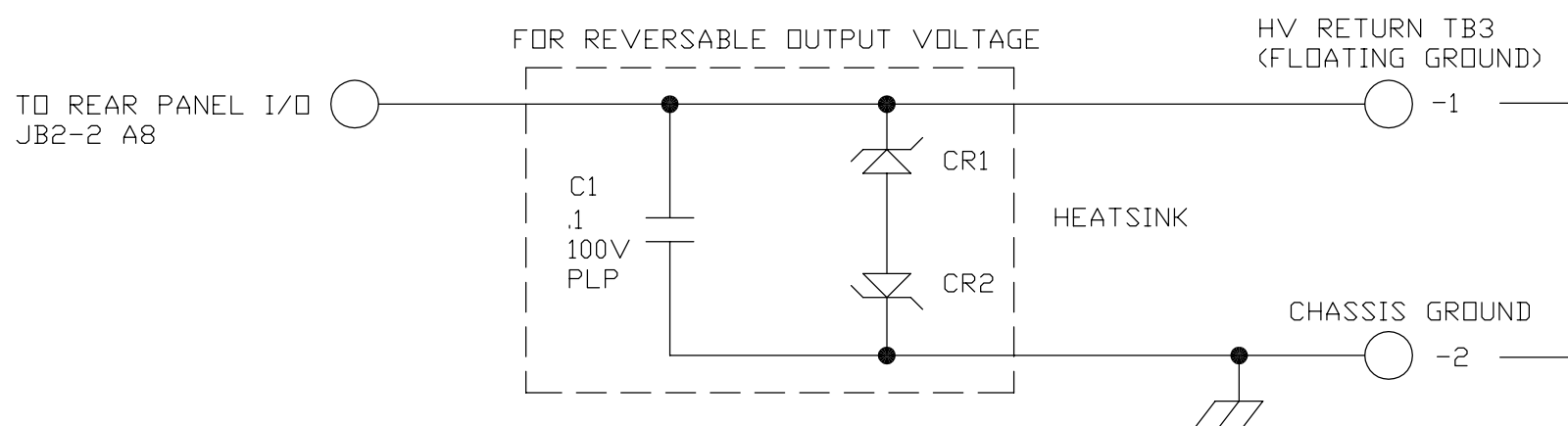
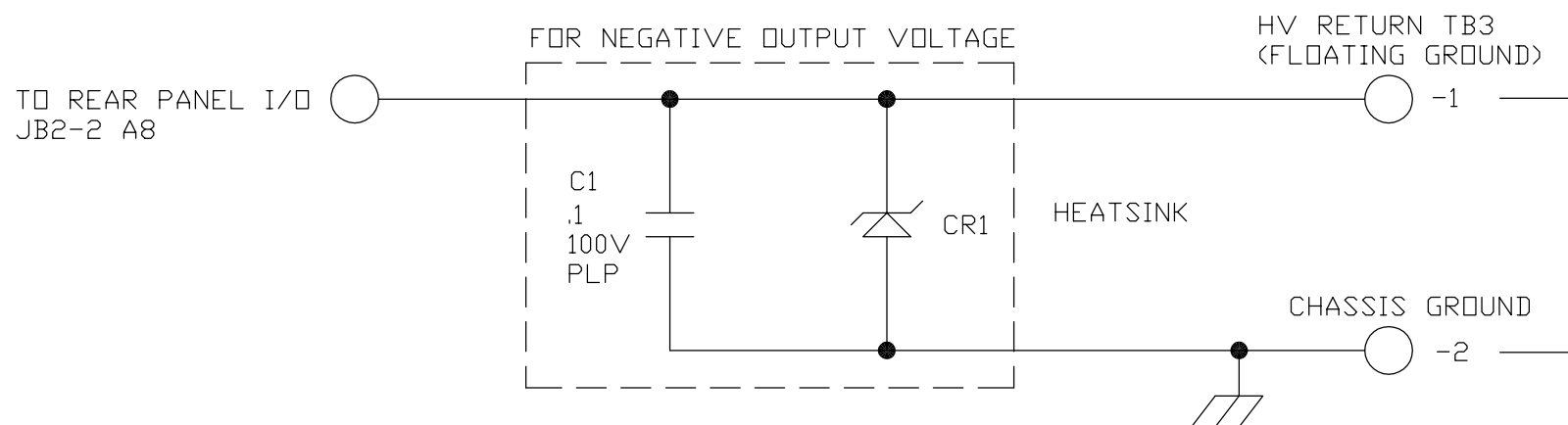
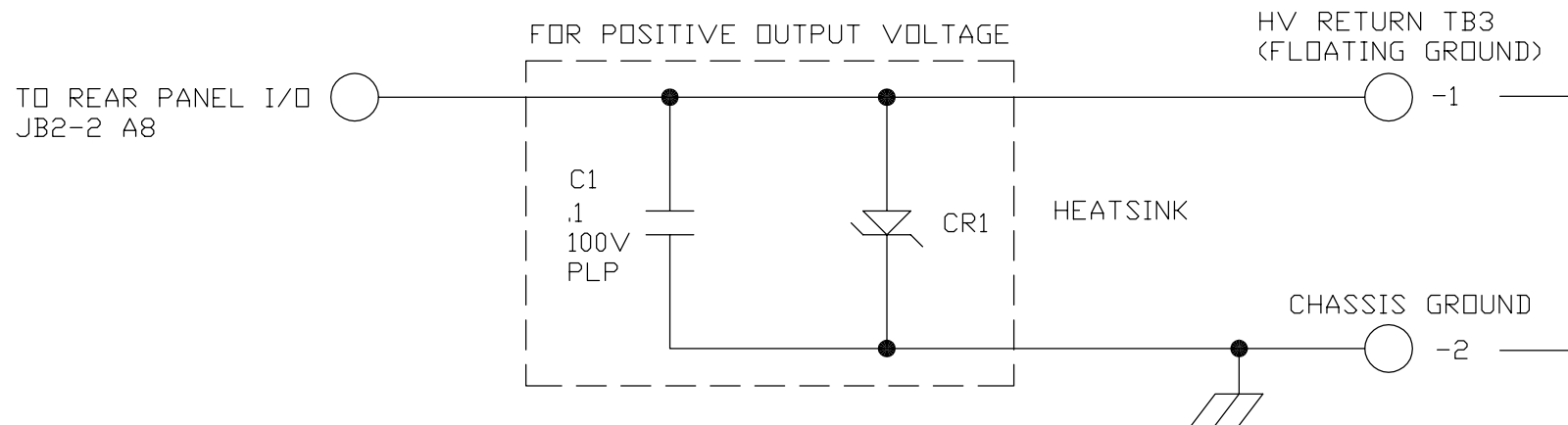

- NOTES:
- FOR 15V MAX FLOATING VOLTAGE CR1 AND CR2 ARE 1N3314.
FOR 62V MAX FLOATING VOLTAGE CR1 AND CR2 ARE 1N3335.
 - POWER DISSIPATION IN CR1 AND CR2 SHOULD NOT EXCEED 25W. THIS CAN BE ACCOMPLISHED BY KEEPING TB3-1, TB3-2 VOLTAGE BELOW ZENER VOLTAGE. TB3 SHIPPED WITH JUMPER.
 - FOR FG OPTION REMOVE E1, E2 GROUNDING POINTS ON SYSTEM CONTROL PWB A5. ADD .1, 100V PLP CAP ACROSS EACH E POINT TO CHASSIS GROUND.

| | | |
|-------------|-----------|---------|
| 340212-001 | - | SR6 |
| PART NO. | NEXT ASSY | USED ON |
| APPLICATION | | |

| | | |
|--|--|---|
| UNLESS OTHERWISE SPECIFIED DIMENSIONS ARE IN INCHES TOLERANCES ARE: FRACTIONS DECIMALS ANGLES ± .XX ± .XXX ± | APPROVALS DRAWN <i>J.S.R.</i> CHECKED <i>N/A</i> MECH. DESIGN <i>N/A</i> PROJ. ENG. <i>B.S.</i> Q.A. <i>N/A</i> MFG. ENG. <i>N/A</i> | DATE 2/6/91 N/A N/A 2/13/91 N/A N/A |
| DO NOT SCALE DRAWING | BREAK ALL SHARP EDGES & CORNERS | SCALE: NONE |

Spellman 475 Wireless Boulevard
Hauppauge, New York 11788

**SCHEMATIC DIAGRAM
FLOATING GROUND OPTION
SR6**

| | | | |
|------|----------------|-------------|-----|
| SIZE | CODE IDENT NO. | DRAWING NO. | REV |
| C | 10610 | 340212-001 | A |

FILE# SHEET 1 OF 1

THIS INFORMATION CONTAINED HEREIN IS PROPRIETARY TO SPELLMAN HIGH VOLTAGE ELECTRONICS CORP. AND IS TO BE USED ONLY FOR THE PURPOSES INTENDED AND IS NOT TO BE REPRODUCED EITHER IN WHOLE OR PART WITHOUT THE EXPRESS WRITTEN PERMISSION OF SPELLMAN HIGH VOLTAGE ELECTRONICS CORP.

| REVISIONS | | APPROVED | | | | |
|-----------|------------------|----------|-------------|----------|---------|---------|
| LTR | DESCRIPTION | DATE | MECH DESIGN | PROJ ENG | QUALITY | MFG ENG |
| A | RELEASED PER EDR | 4/18/91 | T/A | C.S. | X.X. | T/A |

| DESCRIPTION OF HOLES | | |
|----------------------|-------------|-----|
| SYM | DESCRIPTION | QTY |
| | | |

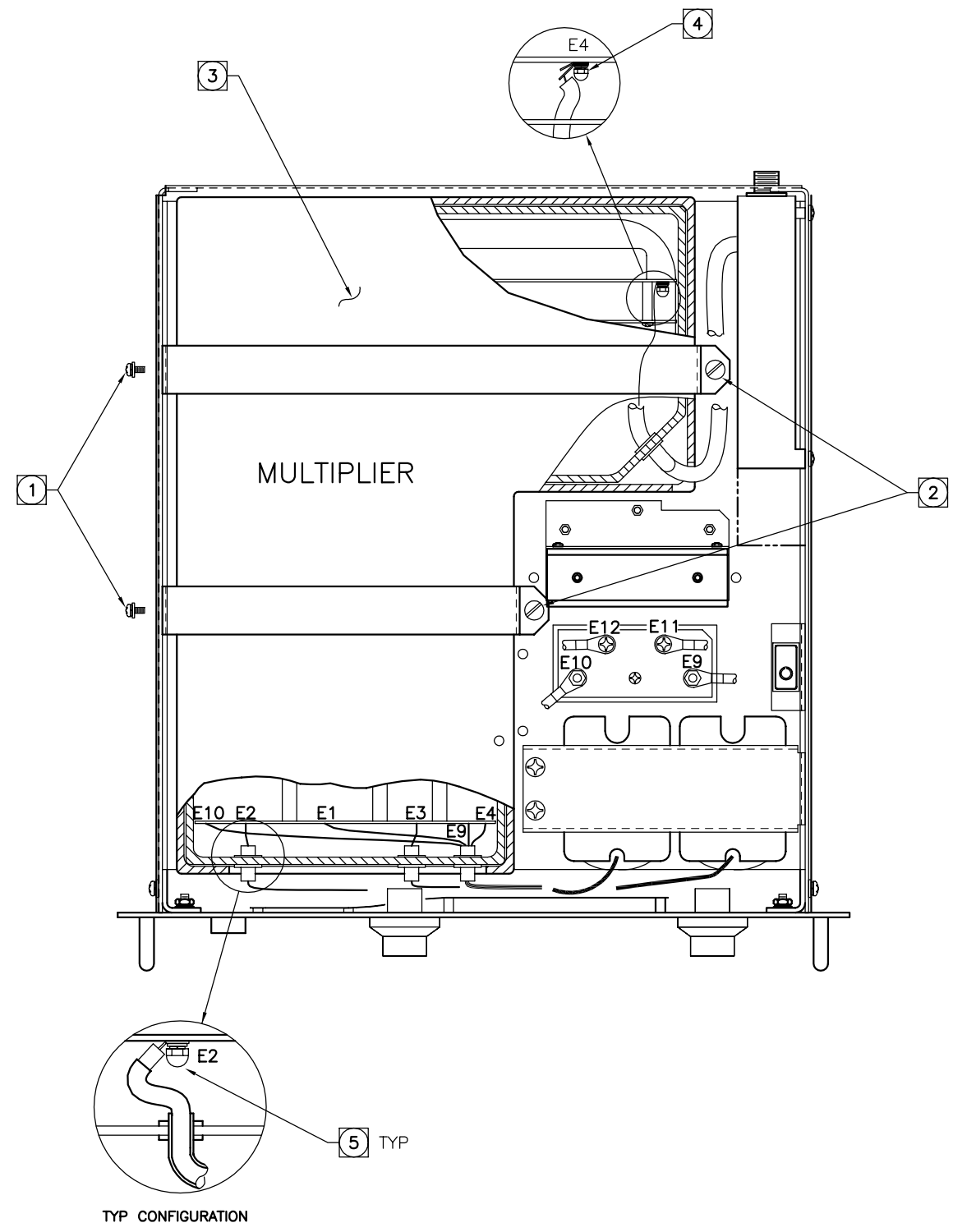

MULTIPLIER IS LOCATED ON BOTTOM HALF OF THE UNIT. REMOVE 6 SCREWS WHICH HOLD BOTTOM COVER AND FOLLOW STEPS 1 THRU 7:

- 1 UNSCREW AND REMOVE SCREWS
- 2 LOOSEN SCREWS AND REMOVE BRACKETS
- 3 REMOVE POLYETHYLENE COVER
- 4 LIFT MULTIPLIER AND UNSCREW HIGH VOLTAGE CABLE(S) FROM E4.
- 5 LIFT MULTIPLIER, UNSCREW AND REMOVE ALL WIRES FROM INPUT BOARD, i.e.
 L1-7 FROM E2
 L2-7 FROM E3
 P1-1 FROM E4
 P1-2 FROM E1
 P1-8 FROM E10
 P1-10 FROM E9
- 6 REMOVE MULTIPLIER FROM POLYETHYLENE ENCLOSURE AND REPLACE WITH ANOTHER ONE.
- 7 FOLLOW STEPS 5 TO 1 IN REVERSE TO FULLY INSTALL THE NEW MULTIPLIER.

| REV STATUS OF PARTS | | | | | | | | | | |
|---------------------|-----|-----|-----|-----|-----|-----|-----|-----|-----|-----|
| DASH NO. | 001 | 002 | 003 | 004 | 005 | 006 | 007 | 008 | 009 | 010 |
| PART | A | | | | | | | | | |
| B.O.M. | | | | | | | | | | |

| UNLESS OTHERWISE SPECIFIED DIMENSIONS ARE IN INCHES TOLERANCES ARE: | | | APPROVALS | | |
|---|----------|--------|---------------|---------|--------------|
| FRACTIONS | DECIMALS | ANGLES | BY | DATE | |
| ± | .XX ± | ± | M. Hayden | 5/16/91 | DRAWN |
| ± | .XXX | ± | S. Pate | 4/18/91 | CHECKED |
| | | | T/A | N/A | MECH. DESIGN |
| | | | C. Scapellato | 4/18/91 | PROJ. ENG. |
| | | | X. Kaufman | 4/19/91 | Q.A. |
| | | | T/A | N/A | MFG. ENG. |

SPELLMAN HIGH VOLTAGE ELECTRONICS CORPORATION
 7 FAIRCHILD AVENUE, PLAINVIEW, NEW YORK 11803

MULTIPLIER REPLACEMENT PROCEDURE SR6

| | | | |
|------|----------------|-------------|-----|
| SIZE | CODE IDENT NO. | DRAWING NO. | REV |
| D | 10610 | 403711-001 | A |

SCALE: 1/2 FILE# 403/711001A1 SHEET 1 OF 1

| PART NO. | NEXT ASSY | USED ON |
|----------|-----------|---------|
| | | |

DO NOT SCALE DRAWING

BREAK ALL SHARP EDGES & CORNERS

THIS INFORMATION CONTAINED HEREIN IS PROPRIETARY TO SPELLMAN HIGH VOLTAGE ELECTRONICS CORP. AND IS TO BE USED ONLY FOR THE PURPOSES INTENDED AND IS NOT TO BE REPRODUCED EITHER IN WHOLE OR PART WITHOUT THE EXPRESS WRITTEN PERMISSION OF SPELLMAN HIGH VOLTAGE ELECTRONICS CORP.

| REVISIONS | | APPROVED | |
|-----------|------------------|----------|-----------------------------|
| LTR | DESCRIPTION | DATE | MECH ENGR PROJ ENGR QUALITY |
| A | RELEASED PER EDR | | |

| DESCRIPTION OF HOLES | | |
|----------------------|-------------|-----|
| SYM | DESCRIPTION | QTY |
| | | |

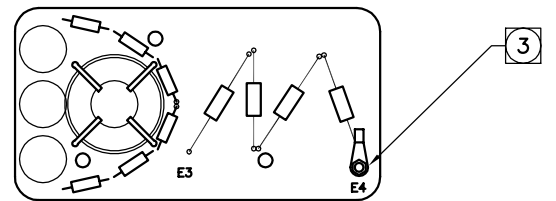

VIEW B-B

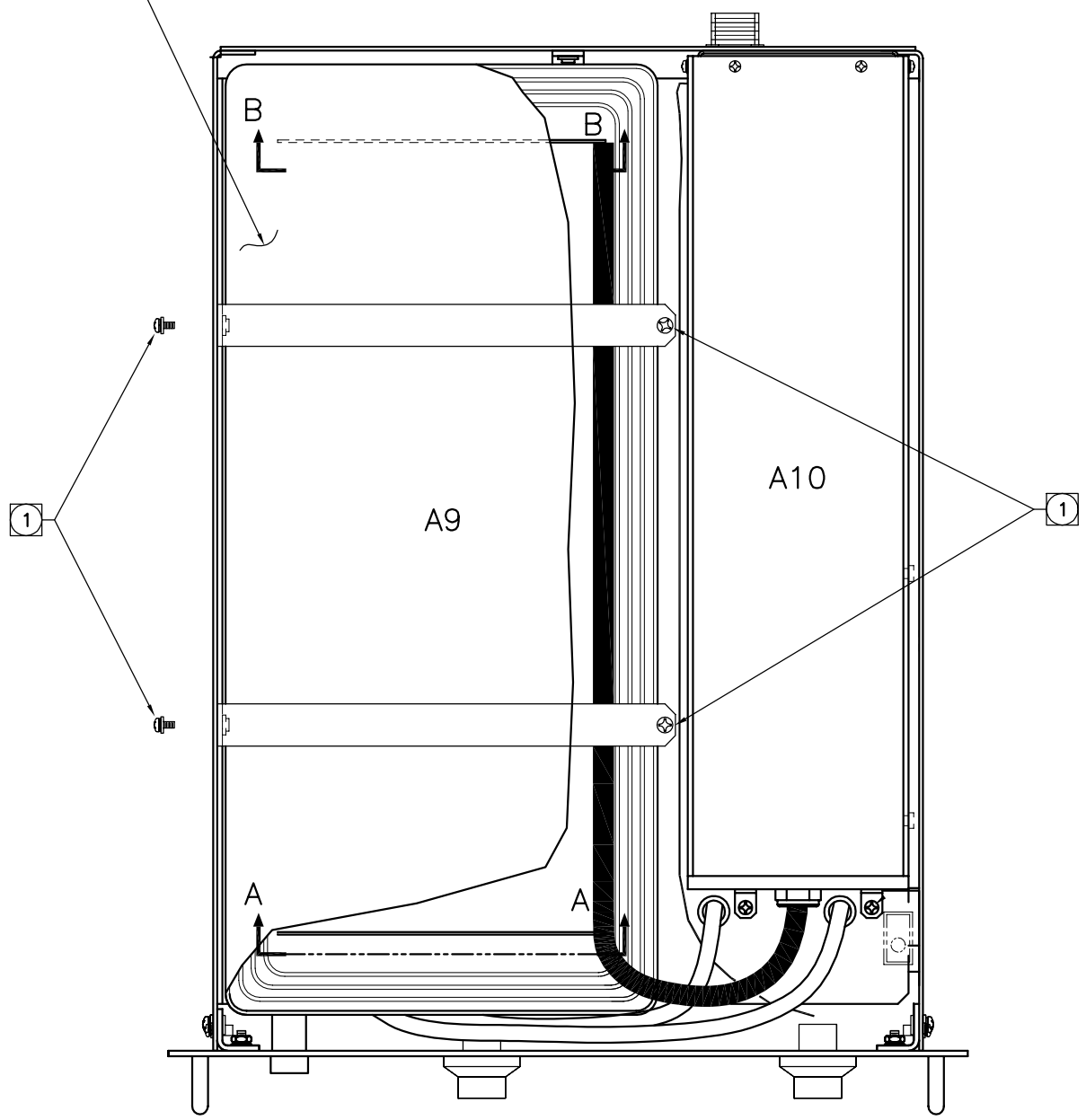

MULTIPLIER IS LOCATED ON BOTTOM HALF OF THE UNIT. REMOVE 6 SCREWS WHICH HOLD BOTTOM COVER AND FOLLOW STEPS 1 THRU 6:

- ① UNSCREW AND REMOVE SCREWS
- ② REMOVE POLYETHYLENE COVERS
- ③ LIFT MULTIPLIER, UNSCREW AND REMOVE HIGH VOLTAGE CABLE FROM E4. DO NOT REMOVE CABLE FROM A10. SEE VIEW B-B
- ④ LIFT MULTIPLIER, UNSCREW AND REMOVE ALL WIRES FROM INPUT BOARD, i.e.
 L1-7 FROM E2
 L2-7 FROM E3
 P1-1 FROM E4
 P1-2 FROM E1
 P1-10 FROM E9
 SEE VIEW A-A
- ⑤ REMOVE MULTIPLIER AND ENCLOSURES AND REPLACE WITH NEW ONE.
- ⑥ FOLLOW STEPS 4 TO 1 IN REVERSE TO FULLY INSTALL THE NEW MULTIPLIER.

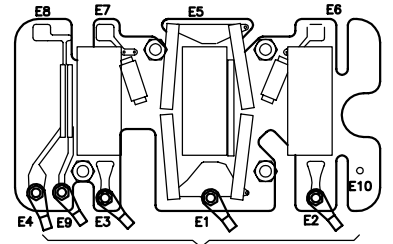

VIEW A-A

| | | | | | | | | | | |
|---|-----------------|----------|------------|-------------------|---------|--|---------------------------------|----------------|-------------|----------|
| UNLESS OTHERWISE SPECIFIED DIMENSIONS ARE IN INCHES TOLERANCES ARE: | | | APPROVALS | | | HIGH VOLTAGE ELECTRONICS CORPORATION 7 FARCHILD AVENUE, PLAINVIEW, NEW YORK 11803 | | | | |
| FRACTIONS ± | DECIMALS .001 ± | ANGLES ± | DRAWN | BY | DATE | PROCEDURE, MULTIPLIER REPLACEMENT SR6, EXTENDED | SIZE | CODE IDENT NO. | DRAWING NO. | A REV |
| | | | CHECKED | <i>M. Haydari</i> | 5/18/93 | | D | 10610 | 403943-001 | |
| MATERIAL | | | DESIGN | | | | FILE# 403\943001A1 SHEET 1 OF 1 | | | |
| FINISH | | | MECH. ENG. | | | | DO NOT SCALE DRAWING | | | |
| | | | PROJ. ENG. | | | | BREAK ALL SHARP EDGES & CORNERS | | | |
| | | | MFG. ENG. | | | | | | | |
| PART NO. | | | NEXT ASSY | | USED ON | | | | | |
| APPLICATION | | | | | | | | | | |

| | | |
|-------------|-----------|---------|
| PART NO. | NEXT ASSY | USED ON |
| APPLICATION | | |

D
C
B
A

D
C
B
A

8

7

6

5

4

3

2

1

8

7

6

5

4

3

2

1

THIS INFORMATION CONTAINED HEREIN IS PROPRIETARY TO SPELLMAN HIGH VOLTAGE ELECTRONICS CORP. AND IS TO BE USED ONLY FOR THE PURPOSES INTENDED AND IS NOT TO BE REPRODUCED EITHER IN WHOLE OR PART WITHOUT THE EXPRESS WRITTEN PERMISSION OF SPELLMAN HIGH VOLTAGE ELECTRONICS CORP.

1&2KV WIRING TABLE III OF V

| AWG COLOR | WIRE ITEM NO. | TERMINATION | | | | SLEEVE | LENGTH ±0.25 |
|--------------|---------------------|--------------|-------------------|----------------------|-------------------|--------|-----------------|
| | | FROM "A" | | TO "B" | | | |
| | | DESIG. | ITEM # OR PREP | DESIG. | ITEM # OR PREP | | |
| - | - | L1-7 | - | A9A3-E1 | 72 | 74 | 12.00 |
| - | - | L2-7 | - | A9A3-E2 | CRIMP&SOLDER | 74 | 16.50 |
| - | - | S3-P1 | - | A9A3-E4 | 13 | - | 10.00 |
| - | - | S3-P2 | - | A9A3-E3 | CRIMP&SOLDER | - | 18.00 |
| - | - | S3-P4 | - | A9A1-A1 | VIEW L-L | - | 4.50 |
| - | - | S3-P3 | - | A9A1-A1 | VIEW L-L | - | 4.50 |
| YEL | 121 | P1-18 | 52 | A9A1-A1 | VIEW L-L | - | 25.00 |
| BLK | 122 | P1-17 | 52 | A9A1-A1 | VIEW L-L | - | 25.00 |
| YEL | 121 | P1-16 | 52 | A9A1-A4 | VIEW L-L | - | 25.00 |
| BLK | 122 | P1-15 | 52 | A9A1-A4 | VIEW L-L | - | 25.00 |
| RED | 124 | P1-9 | 52 | A9A1-A9 | VIEW M-M | - | 18.00 |
| BLU | 123 | P1-11 | 52 | A9A1-A9 | VIEW M-M | - | 20.00 |
| RED | 118 | A9A2-E1 | STRIP3/4" | A9A3-E3 | 13 | 119 | 5.00 |
| RED | 118 | A9A2-E3 | STRIP3/4" | A9A3-E4 | 13 | 119 | 9.00 |
| - | - | L1-6 L2-6 | - | SEE NOTE 9 ON PAGE 4 | | | |

3KV WIRING TABLE IV OF V

| AWG COLOR | WIRE ITEM NO. | TERMINATION | | | | SLEEVE | LENGTH ±0.25 |
|--------------|---------------------|--------------|-------------------|----------------------|-------------------|---------|-----------------|
| | | FROM "A" | | TO "B" | | | |
| | | DESIG. | ITEM # OR PREP | DESIG. | ITEM # OR PREP | | |
| - | - | L1-7 | - | A9A3-E1 | 72 | 74 | 12.00 |
| - | - | L2-7 | - | A9A3-E2 | CRIMP&SOLDER | 74 | 16.50 |
| - | - | S3-P1 | - | A9A3-E4 | 13 | - | 10.00 |
| - | - | S3-P2 | - | A9A3-E3 | CRIMP&SOLDER | - | 18.00 |
| - | - | S3-P4 | - | A9A1-A1 | VIEW L-L | - | 4.50 |
| YEL | 121 | P1-18 | 52 | S3-P3 | NOTE 11 | 129,104 | 15.00 |
| BLK | 122 | P1-17 | 52 | S3-P3 | NOTE 11 | 129,104 | 15.00 |
| YEL | 121 | P1-16 | 52 | A9A1-A1 | VIEW L-L | - | 25.00 |
| BLK | 122 | P1-15 | 52 | A9A1-A1 | VIEW L-L | - | 25.00 |
| RED | 124 | P1-9 | 52 | A9A1-A9 | VIEW M-M | - | 18.00 |
| BLU | 123 | P1-11 | 52 | A9A1-A9 | VIEW M-M | - | 20.00 |
| - | - | L1-6 L2-6 | - | SEE NOTE 9 ON PAGE 4 | | | |

6KV WIRING TABLE V OF V

| AWG COLOR | WIRE ITEM NO. | TERMINATION | | | | SLEEVE | LENGTH ±0.25 |
|--------------|---------------------|--------------|-------------------|----------------|-------------------|---------|-----------------|
| | | FROM "A" | | TO "B" | | | |
| | | DESIG. | ITEM # OR PREP | DESIG. | ITEM # OR PREP | | |
| - | - | L1-7 | - | A9A2-E1 | 72 | 74 | 12.00 |
| - | - | L2-7 | - | A9A2-E2 | CRIMP&SOLDER | 74 | 16.50 |
| - | - | S3-P1 | - | A9A3-E4 | 13 | - | 10.00 |
| - | - | S3-P2 | - | A9A3-E3 | CRIMP&SOLDER | - | 18.00 |
| - | - | S3-P4 | - | A9A1-A1 | VIEW L-L | - | 4.50 |
| BLK | 122 | P1-17 | 52 | S3-P3 | NOTE 11 | 129,104 | 15.00 |
| YEL | 121 | P1-18 | 52 | A9A1-A1 | VIEW L-L | - | 25.00 |
| RED | 124 | P1-9 | 52 | A9A1-A9 | VIEW M-M | - | 18.00 |
| BLU | 123 | P1-11 | 52 | A9A1-A9 | VIEW M-M | - | 20.00 |
| RED | 62 | A9A2-E3 | 13 | A9A3-E1 | 13 | - | 5.00 |
| RED | 62 | A9A2-E4 | 13 | A9A3-E2 | 13 | - | 5.00 |
| - | - | L1-6 L2-6 | - | P1-15 P1-16 | 52 | - | 15.00 17.00 |

OPTION TABLE

| DASH NO. AND REV. | | | | KV MA | DESCRIPTION | A6 | A7 | | A8 | A9 | FRONT PANEL OVERLAY | L1,L2 HV XFMR WINDING | J1,J2 HV CONNECTOR |
|-------------------|-------------------|-------------|-------------------|-----------|---|------------------------------|---|---------------------------------------|--|-------------------------------|-------------------------------|--------------------------|-----------------------|
| PART REV | 1 Ø POS NEG | PART REV | 3 Ø POS NEG | | | SYS CONTROL BD 403445-001 | FRONT PANEL INTERFACE BD 403446-TAB | DECIMAL POINT JUMPERS JP1 & JP2 | REAR PANEL INTERFACE BD 403447-001 | MULTIPLIER ASSY 403514-TAB | HV XFMR WINDING 403517-TAB | HV CONNECTOR | |
| G | 011 | G2 | 001 | 1 6000 | STANDARD MASTER 12KW MASTER 18KW SLAVE POWER OPTION | K68,K54,K95 K68,K54,K96 | 403446-001,JP3(1,2) | JP1 (2,5) | K88 K89 K90 K91 | 403694-001 | 403481-003 403481-002 | 403517-101 | 100132-008 |
| G | 012 | G2 | 002 | 2 3000 | STANDARD MASTER 12KW MASTER 18KW SLAVE POWER OPTION | K69,K55,K95 K69,K55,K96 | 403446-001,JP3(1,2) | JP1 (2,5) | K88 K89 K90 K91 | 403694-002 | 403481-003 403481-002 | 403517-102 | 100132-008 |
| G | 013 | G1 | 003 | 3 2000 | STANDARD MASTER 12KW MASTER 18KW SLAVE POWER OPTION | K70,K56,K95 K70,K56,K96 | 403446-001,JP3(1,2) | JP1 (2,5) | K88 K89 K90 K91 | 403694-003 | 403481-003 403481-002 | 403517-103 | 100132-008 |
| - | 014 | - | 004 | 4 1500 | STANDARD MASTER 12KW MASTER 18KW SLAVE POWER OPTION | K71,K57,K95 K71,K57,K96 | 403446-001,JP3(1,2) | JP1 (N/A) | K88 K89 K90 K91 | 403694-004 | 403481-001 403481-002 | 403517-104 | 100132-008 |
| - | 015 | - | 005 | 5 1200 | STANDARD MASTER 12KW MASTER 18KW SLAVE POWER OPTION | K72,K58,K95 K72,K58,K96 | 403446-001,JP3(1,2) | JP1 (N/A) | K88 K89 K90 K91 | 403694-005 | 403481-001 403481-002 | 403517-105 | 100132-008 |
| G | 016 | G1 | 006 | 6 1000 | STANDARD MASTER 12KW MASTER 18KW SLAVE POWER OPTION | K72,K58,K95 K72,K58,K96 | 403446-001,JP3(1,2) | JP1 (N/A) | K88 K89 K90 K91 | 403694-006 | 403481-001 403481-002 | 403517-001 | 100132-008 |

SPELLMAN HIGH VOLTAGE ELECTRONICS CORPORATION
475 WIRELESS BLVD. HAUPPAUGE, NEW YORK 11788

**POWER SUPPLY ASSEMBLY
LOW KV
SR6**

| | | | |
|------|----------------|-------------|-----|
| SIZE | CODE IDENT NO. | DRAWING NO. | REV |
| D | 10610 | 403689-TAB | G2 |

SCALE: 1/1 FILE# 403\689TABFG2 SHEET 5 OF 5

THIS INFORMATION CONTAINED HEREIN IS PROPRIETARY TO SPELLMAN HIGH VOLTAGE ELECTRONICS CORP. AND IS TO BE USED ONLY FOR THE PURPOSES INTENDED AND IS NOT TO BE REPRODUCED EITHER IN WHOLE OR PART WITHOUT THE EXPRESS WRITTEN PERMISSION OF SPELLMAN HIGH VOLTAGE ELECTRONICS CORP.

| REVISIONS | | APPROVED | | | | |
|-----------|-----------------------|----------|-------------|----------|---------|---------|
| LTR | DESCRIPTION | DATE | MECH DESIGN | PROJ ENG | QUALITY | MFG ENG |
| A | RELEASED PER EDR 4118 | 8/10/96 | M.M. | J.P. | K.K. | J.J. |
| A1 | REVISED PER ECN 11077 | 11/25/97 | M.M. | N/A | K.K. | L.S. |

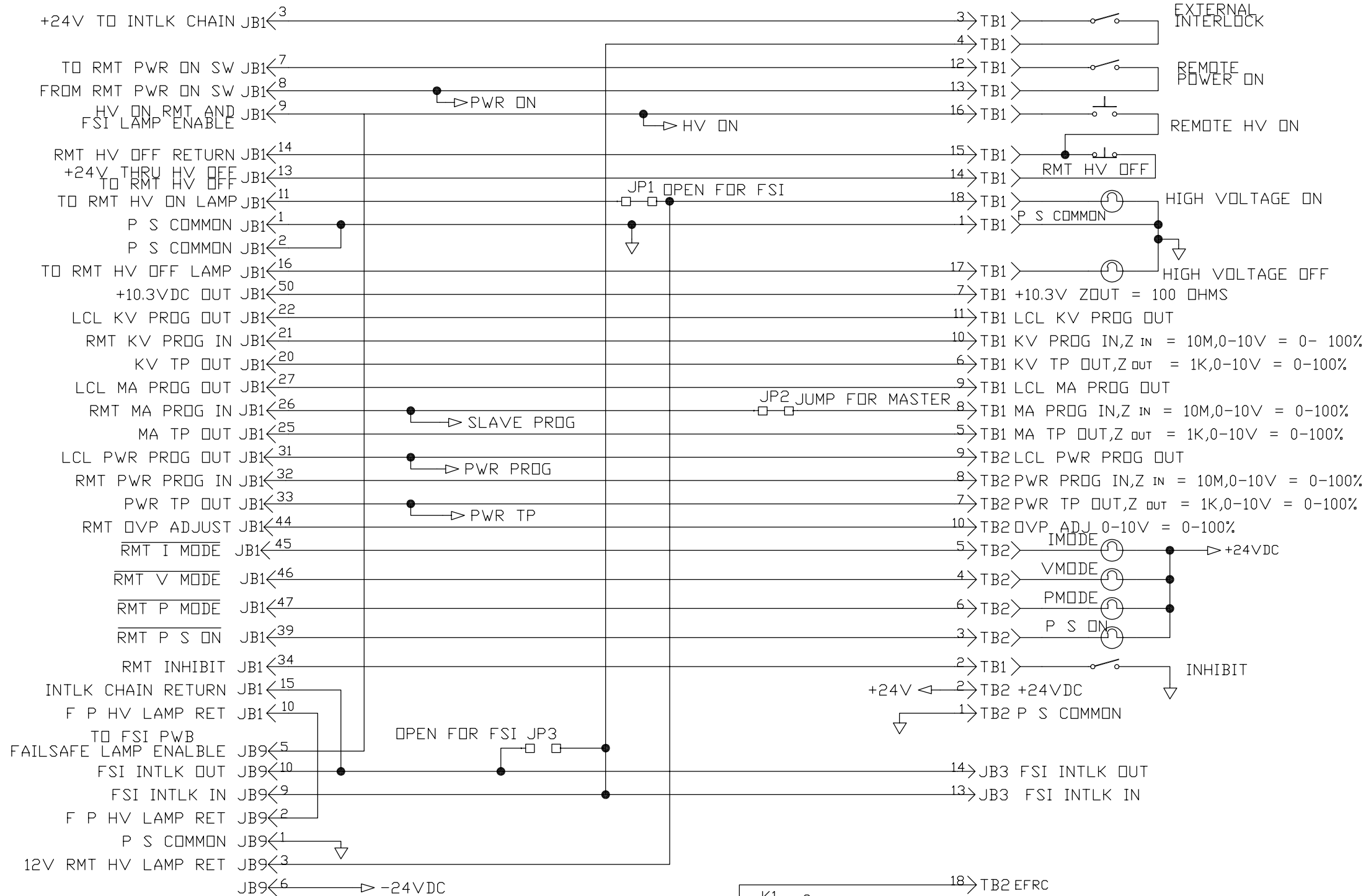

| APPROVALS | | |
|-----------|------|---------|
| BY | DATE | |
| DRWN | M.M. | 4/17/96 |
| CHEK | N/A | N/A |
| MECH | M.M. | 6/17/96 |
| PROJ | J.P. | 6/20/96 |
| QA | K.K. | 8/10/96 |
| MFG | J.J. | 8/10/96 |

Spellman 475 Wireless Boulevard
Hauppauge, New York 11788

SCHEMATIC DIAGRAM
REAR PANEL INTERFACE
SR6 - 30kW

| | | |
|------|----------------|-------------|
| SIZE | CODE IDENT NO. | DRAWING NO. |
| D | 10610 | 440689-001 |
| REV | | A1 |

| PART NO. | NEXT ASSY | USED ON |
|-------------|------------|------------|
| 440689-001 | 404596-001 | SR6 - 30kW |
| APPLICATION | | |

DO NOT SCALE DRAWING BREAK ALL SHARP EDGES & CORNERS SCALE: NONE FILE# SHEET 1 OF 2

THIS INFORMATION CONTAINED HEREIN IS PROPRIETARY TO SPELLMAN HIGH VOLTAGE ELECTRONICS CORP. AND IS TO BE USED ONLY FOR THE PURPOSES INTENDED AND IS NOT TO BE REPRODUCED EITHER IN WHOLE OR PART WITHOUT THE EXPRESS WRITTEN PERMISSION OF SPELLMAN HIGH VOLTAGE ELECTRONICS CORP.

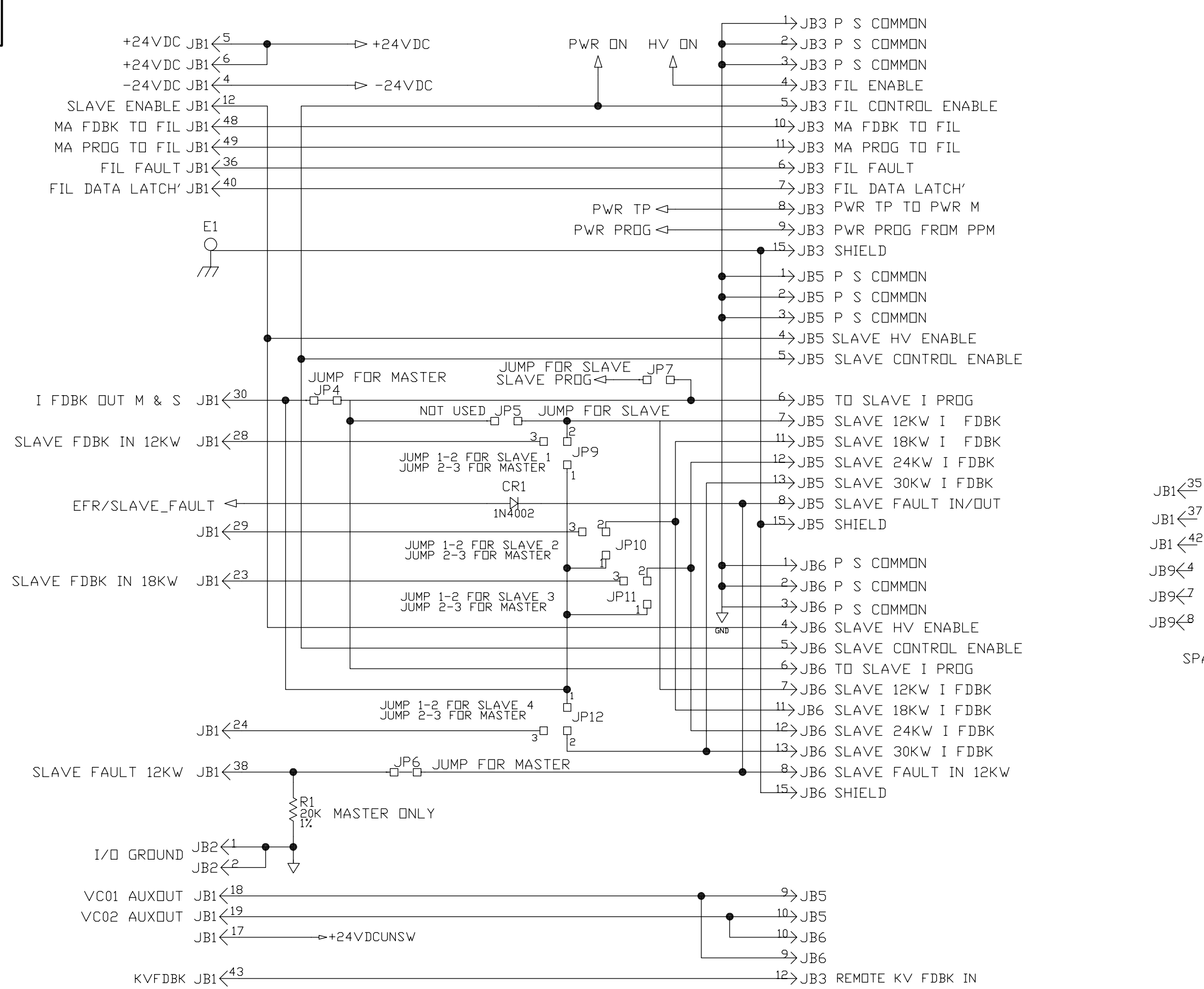

- TB2 ¹¹
 - JB1 ³⁵ TB2 ¹²
 - JB1 ³⁷ TB2 ¹³
 - JB1 ⁴² TB2 ¹⁴
 - JB9 ⁴ TB2 ¹⁵
 - JB9 ⁷ JB5 ¹⁴
 - JB9 ⁸ JB6 ¹⁴
- SPARES

| | | | |
|--|----------------|---|-----|
| Spellman | | 475 Wireless Boulevard Hauppauge, New York 11788 | |
| SCHEMATIC DIAGRAM REAR PANEL INTERFACE SR6 - 30kW | | | |
| SIZE | CODE IDENT NO. | DRAWING NO. | REV |
| D | 10610 | 440689-001 | A1 |
| SCALE: NONE | FILE# | SHEET 2 OF 2 | |

THIS INFORMATION CONTAINED HEREIN IS PROPRIETARY TO SPELLMAN HIGH VOLTAGE ELECTRONICS CORP. AND IS TO BE USED ONLY FOR THE PURPOSES INTENDED AND IS NOT TO BE REPRODUCED EITHER IN WHOLE OR PART WITHOUT THE EXPRESS WRITTEN PERMISSION OF SPELLMAN HIGH VOLTAGE ELECTRONICS CORP.

| REVISIONS | | | APPROVED | |
|-----------|-----------------------|---------|------------|---------|
| LTR | DESCRIPTION | DATE | PROJ. ENG. | QUALITY |
| A | RELEASED PER EDR 2793 | 4/16/91 | C.S. | J.C. |

| DESCRIPTION OF HOLES | | |
|----------------------|-------------|-----|
| SYM | DESCRIPTION | QTY |
| | | |

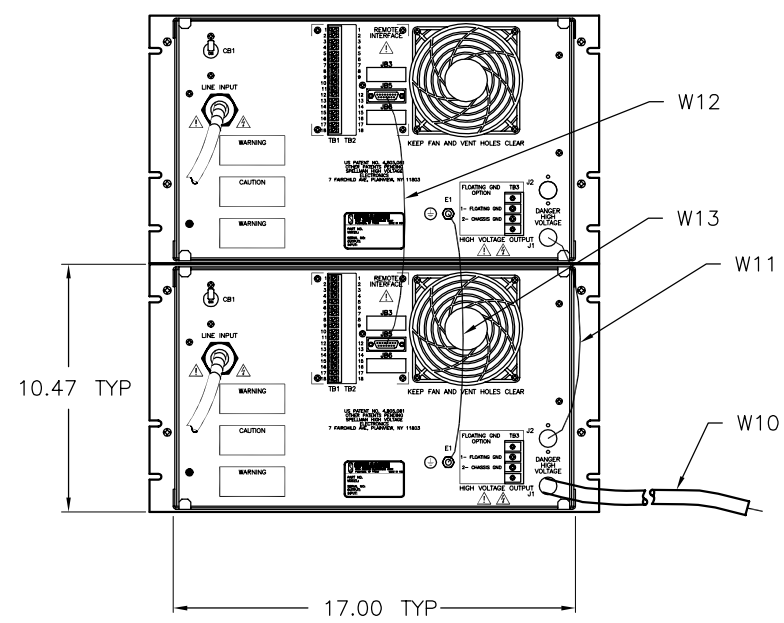
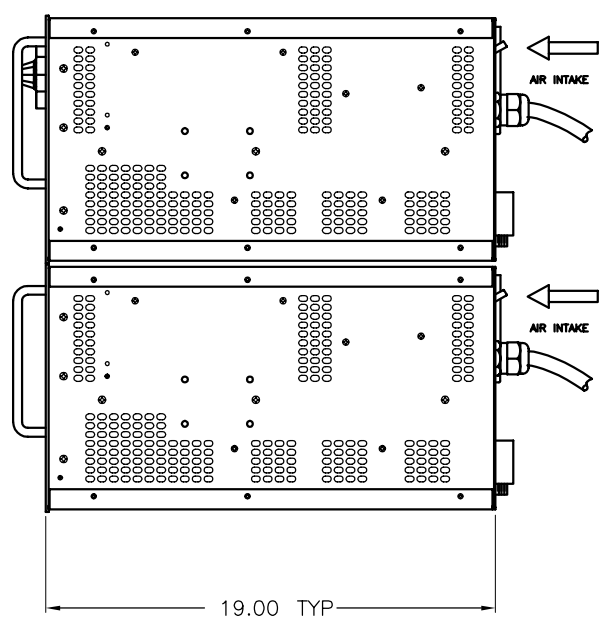
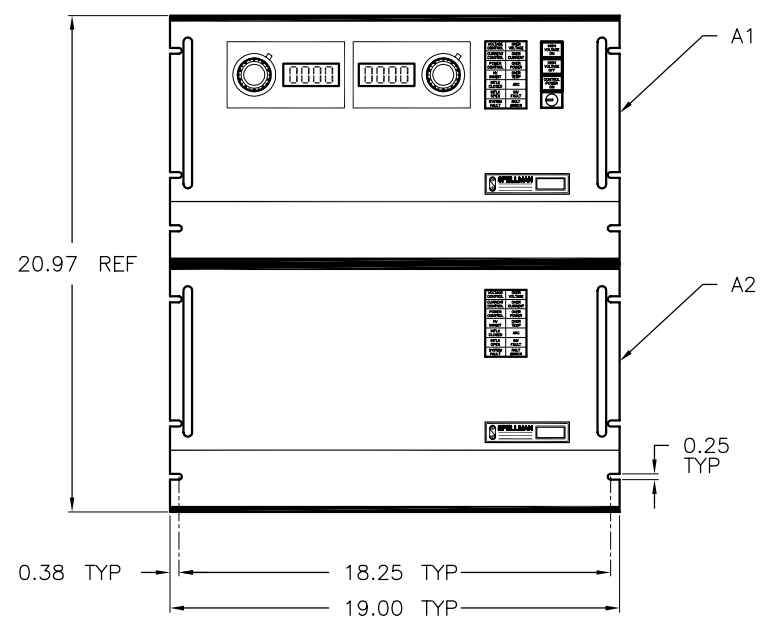

STANDARD 19" RACK PANELS
PER EIA STD RS-310
ALL DIMENSIONS ARE
FOR REF ONLY

| REV STATUS OF PARTS | | | | | | | | | | |
|---------------------|-----|-----|-----|-----|-----|-----|-----|-----|-----|-----|
| DASH NO. | 001 | 002 | 003 | 004 | 005 | 006 | 007 | 008 | 009 | 010 |
| PART | A | | | | | | | | | |
| B.O.M. | | | | | | | | | | |

| UNLESS OTHERWISE SPECIFIED DIMENSIONS ARE IN INCHES TOLERANCES ARE: | | | CONTRACT NO. | | |
|---|----------|--------|--------------|------------|----------|
| FRACTIONS | DECIMALS | ANGLES | APPROVALS | | |
| ± | .XX ± | ± | BY | DATE | |
| | .XXX ± | | DRAWN | M. Saydari | 12/10/90 |
| | | | CHECKED | Y/A | N/A |
| | | | DESIGN | S.P. | 4/18/91 |
| | | | PROJ. ENG. | C.S. | 4/16/91 |
| | | | G.A. | J.C. | 4/18/91 |
| | | | | | |

SPELLMAN HIGH VOLTAGE ELECTRONICS CORPORATION
7 FAIRCHILD AVENUE, PLAINFIELD, NEW YORK 11803

**POWER SUPPLY
INSTALLATION DRAWING
SR12KW**

| | | | |
|------|----------------|-------------|-----|
| SIZE | CODE IDENT NO. | DRAWING NO. | REV |
| D | 10610 | 403641-TAB | A |

SCALE: 1/4 FILE# 403\641TAB1 SHEET 1 OF 1

| PART NO. | NEXT ASSY | USED ON |
|----------|-----------|---------|
| | | |
| | | |
| | | |
| | | |
| | | |
| | | |

THIS INFORMATION CONTAINED HEREIN IS PROPRIETARY TO SPELLMAN HIGH VOLTAGE ELECTRONICS CORP. AND IS TO BE USED ONLY FOR THE PURPOSES INTENDED AND IS NOT TO BE REPRODUCED EITHER IN WHOLE OR PART WITHOUT THE EXPRESS WRITTEN PERMISSION OF SPELLMAN HIGH VOLTAGE ELECTRONICS CORP.

| REVISIONS | | APPROVED | |
|-----------|-----------------------|----------|-----------------------------|
| LTR | DESCRIPTION | DATE | MECH ENGR PROJ ENGR QUALITY |
| A | RELEASED PER EDR 2793 | 4/18/91 | 77.7% C.S. X.C. |

| DESCRIPTION OF HOLES | | |
|----------------------|-------------|-----|
| SYM | DESCRIPTION | QTY |
| | | |

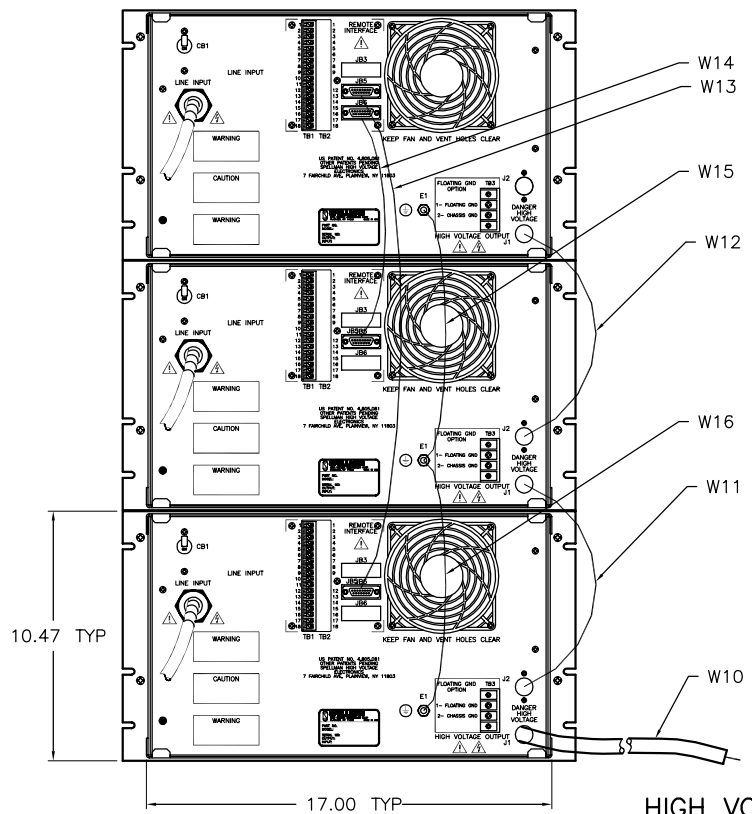
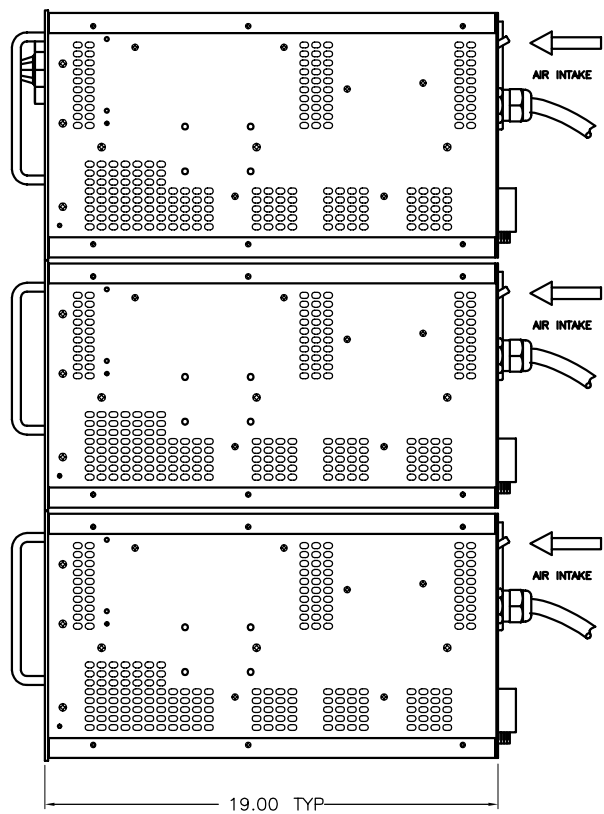
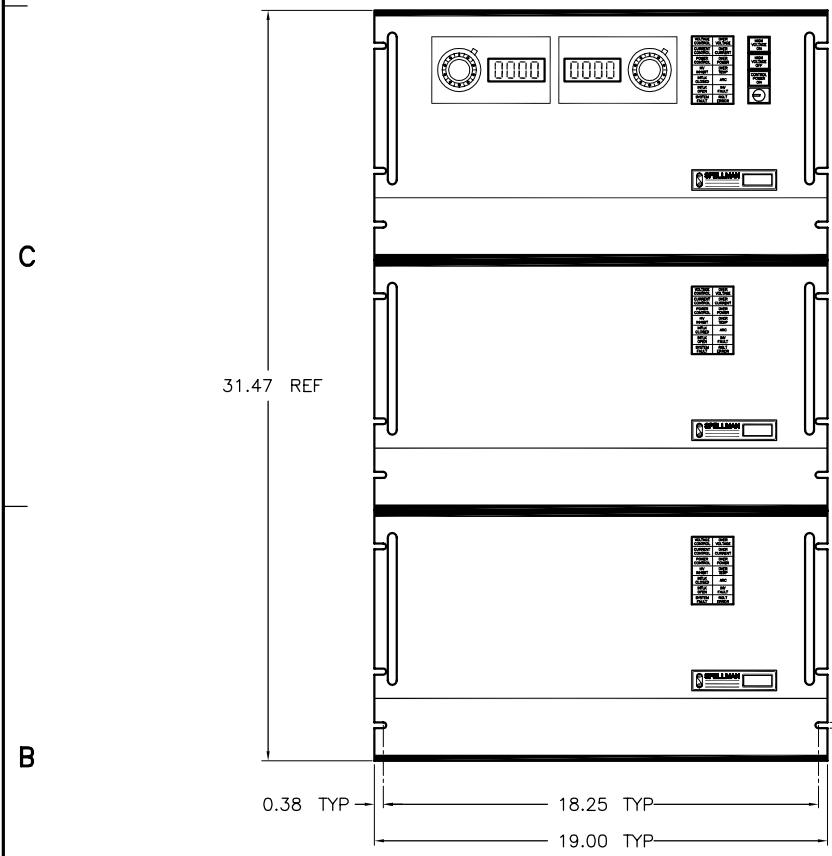

STANDARD 19" RACK PANELS
PER E1A STD RS-310
ALL DIMENSIONS ARE
FOR REF ONLY

| PART NO. | NEXT ASSY | USED ON | APPLICATION | | |
|----------|-----------|---------|-------------|--|--|
| | | | | | |
| | | | | | |
| | | | | | |
| | | | | | |
| | | | | | |

| UNLESS OTHERWISE SPECIFIED DIMENSIONS ARE IN INCHES TOLERANCES ARE: | | |
|---|-----------------|--------|
| FRACTIONS | DECIMALS | ANGLES |
| ± | .XX ± .XXX ± | ± |

| | | |
|--------------|----------------|--|
| CONTRACT NO. | | HIGH VOLTAGE ELECTRONICS CORPORATION 7 FAIRCHILD AVENUE, PLAINFIELD, NEW YORK 11603 |
| APPROVALS | | |
| DRAWN | BY | DATE |
| CHECKED | <i>N/A</i> | <i>N/A</i> |
| DESIGN | <i>S.P.</i> | 4/18/91 |
| MECH. ENG. | <i>M.S.</i> | 4/18/91 |
| PROJ. ENG. | <i>C.S.</i> | 4/18/91 |
| Q.A. | <i>X.C.</i> | 4/19/91 |
| SIZE | CODE IDENT NO. | DRAWING NO. |
| D | 10610 | 403712-TAB |
| SCALE: 1/4 | | FILE# 403\712TAB1 |
| SHEET 1 | | OF 1 |